

HANDBIKE BATEC ELECTRIC

- MINI 2
- MINI
- ELECTRIC 2 (RAPID 2)
- SCRAMBLER



Distributed in Canada by
49 Bespoke Inc.
51 Caldari Road, Units 6-7B
Concord, ON L4K 4G3, Canada
Telephone: +1.866.827.4548
Fax: +1.877.731.7745
E-Mail: 49@49bespoke.com
www.49bespoke.com

CONTENTS

Welcome.....	5
1.Intended purpose, indications and contraindications.....	6
2.Safety measures and general precautions.....	8
2.1. Before using your HANDBIKE BATEC ELECTRIC for the first time..	8
2.2. During use.....	9
2.3. General precautions	13
2.4. Lifespan	13
3.Models: characteristics and parts.....	14
3.1. HANDBIKE BATEC ELECTRIC MINI 2 / MINI / ELECTRIC 2	
(RAPID 2) / SCRAMBLER	15
3.1.1. Characteristics	15
MINI 2	15
MINI	17
ELECTRIC 2	18
RAPID 2	19
SCRAMBLER	20
3.1.2. Parts of the HANDBIKE BATEC ELECTRIC MINI 2 / MINI /	
ELECTRIC 2 (RAPID 2) / SCRAMBLER	21
3.1.3. Parts of the HANDBIKE BATEC ELECTRIC QUAD	
MINI 2 / MINI / ELECTRIC 2 (RAPID 2) / SCRAMBLER.....	21
3.1.4. Parts of the HEMI control for the HANDBIKE BATEC	
ELECTRIC MINI 2 / MINI / ELECTRIC 2 (RAPID 2) /	
SCRAMBLER	21
4.Operating the batec handbike / user guide.....	22
4.1. Delivery	22
4.2. Unpacking	22
4.3. Elevation, transport and storage	22
4.4. Attaching the HANDBIKE BATEC ELECTRIC	23
4.5. Detaching the HANDBIKE BATEC ELECTRIC	24

- 4.6. Using the HANDBIKE BATEC ELECTRIC MINI 2 / MINI /
ELECTRIC 2 (RAPID 2) / SCRAMBLER CONTROLS 24
- 4.7. Using the HANDBIKE BATEC ELECTRIC QUAD MINI 2 / MINI /
ELECTRIC 2 (RAPID 2) / SCRAMBLER CONTROLS 25
- 4.8. Operating the HANDBIKE BATEC ELECTRIC MINI 2 / MINI /
ELECTRIC 2 (RAPID 2) / SCRAMBLER HEMI controls 26
- 4.9. Battery 27
 - 4.9.1. Basic battery use 28
 - 4.9.2. Battery safety information 30
 - 4.9.3. Additional information on the battery 31
 - 4.9.4. Technical specifications of the 280 Wh battery 33
 - 4.9.5. Technical specifications of the 522 Wh battery 33
 - 4.9.6. Specifications of the 679 Wh battery 34
- 4.10. Weights 34
- 5. Installation and adjustments 36
 - 5.1. Installation of the HANDBIKE BATEC ELECTRIC
on a wheelchair 36
 - 5.2. User adjustments 36
 - 5.2.1. Adjust the distance between the HANDBIKE BATEC
ELECTRIC and the chair..... 37
 - 5.2.2. Adjust stem angle 37
 - 5.2.3. Adjust stem height 37
 - 5.2.4. LCD console adjustments 37
- 6. Maintenance and repairs 40
- 7. Label 46
- 8. Warranty 47
 - 8.1. Warranty period 47
 - 8.2. Warranty conditions 47
 - 8.3. Warranty card 49
- 9. Revisions list 50

WELCOME

First of all, we'd like to congratulate you on your purchase of a HAND-BIKE BATEC ELECTRIC, manufactured by BATEC MOBILITY S.L.

All of the products designed, manufactured and distributed by BATEC MOBILITY comply with European Regulation (EU) 2017/745 concerning medical devices and the amendments in 2007/47/EC.

Each HANDBIKE BATEC ELECTRIC is assembled individually by hand, to ensure maximum quality. The fact that the inventor, founder and current director of BATEC MOBILITY and many of our employees are HANDBIKE BATEC ELECTRIC users allows us to apply our direct experience gained over many years of use to our products.

Here at BATEC MOBILITY we're committed to ensuring that each new user gets the most out of their HANDBIKE BATEC ELECTRIC, thus gaining greater mobility and independence.

It is very important that you read this manual and the safety instructions carefully before using the product. This will help you understand how your HANDBIKE BATEC ELECTRIC is made and how you should use it for maximum comfort and safety.

For our part, we're available at any time to answer any questions you may have or provide any services you may need.

1. INTENDED PURPOSE, INDICATIONS AND CONTRAINDICATIONS

The HANDBIKE BATEC ELECTRIC is a handbike that attaches to a wheelchair to create a three-wheeled vehicle that allows users to move around propelled only by their arms, optimising their capacities and boosting autonomy.

HANDBIKE BATEC ELECTRIC has CE marking as a class I medical device according to the requirements of Regulation (EU) 2017/745 concerning medical devices and the amendments in 2007/47/EC.

All the HANDBIKE BATEC ELECTRIC models operate in a similar manner, the only change being the wheel size, top speed and features. See Section 3 (MODELS).

First, the handbike must be attached to a wheelchair. Once the two parts have been joined, we have a three-wheeled vehicle with the seat on the wheelchair and transmission and traction on the front wheel. To operate the handbike, just activate its transmission by pedalling with your hands or pressing on the accelerator. This will provide traction to the front wheel.

This product aims to provide wheelchair users (people with a disability that makes it impossible for them to walk) with attractive, practical products that are useful both in their daily life and for doing recreational activities and sport.

Thanks to the product configuration, users can do longer and more complicated trips than with a wheelchair alone, boosting independence and autonomy.

INDICATIONS

The HANDBIKE BATEC ELECTRIC is indicated for users with the following characteristics:

- With a disability affecting the lower limbs, who use a wheelchair and whose upper limbs are not affected and have full functionality of their hands. For these users, models with either the standard or PARA set-up are indicated.
- With a disability affecting the lower limbs, who use a wheelchair and whose upper limbs are partially affected and have good functionality of their arms and partial functionality of their hands, enough to accelerate, brake and turn without risk. For these users, models with the TETRA set-up are indicated. For those with spinal injuries, the most severe level that can use models with the TETRA set-up is functional C6. It is essential to have good biceps function and firm wrist extension.
- With a total or partial disability affecting the lower limbs, who use a wheelchair and whose upper limbs are partially affected and have full functionality (arm and hand) on at least one side. For these users, models with the HEMI set-up are indicated.

CONTRAINDICATIONS

Use of the product is contraindicated for people whose physical and/or psychological condition does not allow them to move around safely in situations with traffic.

2. SAFETY MEASURES AND GENERAL PRECAUTIONS

2.1. BEFORE USING YOUR BATEC HANDBIKE FOR THE FIRST TIME

IMPORTANT!

Before using your HANDBIKE BATEC ELECTRIC for the first time, read this user manual carefully.

- Don't exceed the maximum weight of 110 kg. This includes the user's weight and any other object being carried.
- The HANDBIKE BATEC ELECTRIC isn't compatible with all wheelchairs on the market. Before installing it, check the current BATEC Compatibility Table on our website (www.batec-mobility.com).
- It is important to start out slowly the first time you use your HAND-BIKE BATEC ELECTRIC in order to learn the sensations you get and become familiar with it. Each new manoeuvre is a potential risk. Be particularly careful with turns and speed.
- Choose a calm place to use your HANDBIKE BATEC ELECTRIC the first time.
- Have someone help you become familiar with your HANDBIKE BATEC ELECTRIC. Each new manoeuvre can put you at risk of injury. Never use your HANDBIKE BATEC ELECTRIC alone until you have gained the necessary skill level. When someone is helping you, it is important for them to have read the user manual before-hand as well.
- Safe use of the HANDBIKE BATEC ELECTRIC requires training and experience.

- The HANDBIKE BATEC ELECTRIC is a medical device classified as a technical aid for mobility and we recommend consulting your local regulations on the circulation of such vehicles. BATEC MOBILITY S.L. can provide you with the Declaration of Conformity as a medical device or certification as a technical aid, if required.
- Check local laws regarding add-on handbikes and wheelchairs, as they may vary depending on your location.
- Always do a safety check on your HANDBIKE BATEC ELECTRIC before each use. To do this, check:
 - Conditions of the fixed or removable axles on the rear wheels of your wheelchair.
 - The Velcro on the seat and backrest of your wheelchair.
 - Tyre pressure on your wheelchair. If it is too low, there is a greater risk of tipping over and greater wear (recommended pressure for wheelchair: see side of tyre).
 - HANDBIKE BATEC ELECTRIC tyre pressure (recommended pressure: depends on model).
 - Conditions of the HANDBIKE BATEC ELECTRIC frame.
 - All parts, in particular any screws, are properly tightened.
 - Brakes are working properly.
 - Make sure that all electrical connections are in good conditions and properly connected.
 - Make sure the battery is connected.
 - The HANDBIKE BATEC ELECTRIC attaches and detaches from the wheelchair properly.

2.2. DURING USE

- The HANDBIKE BATEC ELECTRIC must only be used to transport one person at a time.
- The HANDBIKE BATEC ELECTRIC is only recommended for people with the physical and mental state necessary to travel in situations with vehicle traffic.

- Avoid unnecessary risks like excess speed, fast turns and leaning to the side. Also avoid travelling over objects that may cause you to brake sharply or tip over.
- The safest way to drive the HANDBIKE BATEC ELECTRIC is on level surfaces without obstacles. Use ramps whenever possible. Always be extremely careful when crossing the road.
- Use reflectors on your HANDBIKE BATEC ELECTRIC and wheelchair or on your clothes to make you more visible to drivers. In situations with reduced visibility, always use lights.
- There is a risk of skidding on wet surfaces, gravel or irregular terrain, reduce your speed and use extra caution. Don't use the HANDBIKE BATEC ELECTRIC on mud or ice.
- Make sure your feet are properly positioned on the footrest of the wheelchair and that the seatbelt is properly adjusted.
- We strongly recommend you wear helmet when travelling over 10 km/h.
- When you use your HANDBIKE BATEC ELECTRIC, control your speed and only ride as fast as appropriate for the given ground conditions. By maintaining a prudent speed, you will avoid unnecessary risks. Don't ride the HANDBIKE BATEC ELECTRIC faster than you would travel in a wheelchair alone.
- Maximum recommended speeds are:
 - 6 km/h on the street, pavement and pedestrian areas.
 - 12 km/h in cycle lanes.
 - >12 km/h on private land.
- When you need to turn, remember to slow down and be extra care-ful. If you take a turn too quickly, you may lose control of the HAND-BIKE BATEC ELECTRIC and run the risk of tipping over or crashing. Lean your body into the curve for better stability and to reduce the risk of tipping over.
- While driving and braking, hold the grips firmly with both hands in order to avoid any accidents caused by steering error.
- Going up or down kerbs isn't recommended, as there is a risk of tip-ping over. When you can't avoid a kerb, we recommend you:
 - Get help whenever possible.
 - Take the kerb perpendicularly, so that both wheels of your wheel-chair go over the kerb at the same time. Going over a kerb in any other way significantly increases the risk of tipping over.
 - Avoid banging the HANDBIKE BATEC ELECTRIC when going up or down over a kerb, as this could damage both the HANDBIKE BATEC ELECTRIC and your wheelchair.
 - The HANDBIKE BATEC ELECTRIC and the wheelchair must roll gen-tly over the kerb on all wheels.
 - Never try to go up or down over any kerb more than 10 cm high.
- When travelling up or down a hill, we recommend you:
 - Get help whenever possible while on a hill.
 - Stay a straight course.
 - When going up steep hills, lean forward to put more weight on the front wheel and improve traction.
 - Avoid unnecessary turns and never turn sharply, as this puts you at risk of tipping over.
 - Avoid stopping: this may lead you to lose control of the HANDBIKE BATEC ELECTRIC.
 - When going downhill, go slowly, braking continuously, and avoid braking sharply.
 - Don't use the brakes on your wheelchair; this could cause them to lock up and you to lose control.
 - The maximum recommended slope is 10°, as steeper inclines could make the parking brake less effective. Also take into account that the safe braking distance on hills can be much longer than on flat terrain.
- When travelling long distances we recommend you carry an extra battery.

- Make sure the grip on your wheels is proper conditions.
- Make sure you are familiar with braking distances at various speeds.
- Only use accessories approved by BATEC MOBILITY. Check www.batec-mobility.com.
- NEVER use your HANDBIKE BATEC ELECTRIC with a child on your lap, as there is a high risk
- The BATEC ELECTRIC HANDBIKE could be affected by electromagnetic fields (for example, shop alarm systems, automatic doors, etc.) and its handling could also be affected by electromagnetic fields (for example, mobile phones, electric generators and high-voltage power sources).
- The following manoeuvres are not allowed:
 - Riding up or down stairs or staircases.
 - Riding at an angle on the pavement.
 - 180° turns on steep hills.
 - Sharp movements.
 - Sharp braking on a curve.

.....

→ IMPORTANT!

There is a risk that fingers may get smashed in several parts of the product (openings and spaces between fixed accessible parts) during intended use. (See fig. 1, 2)

.....

→ IMPORTANT!

There is a risk that feet may get smashed (openings and spaces between fixed accessible parts) during intended use. (See fig. 3)

.....

2.3. GENERAL PRECAUTIONS

- Remember to always turn off the BATEC ELECTRIC HANDBIKE before attaching or detaching it to the wheelchair.
- Do not use the BATEC ELECTRIC HANDBIKE if it behaves abnormally or erratically.
- Do not use the BATEC ELECTRIC HANDBIKE with dead batteries.
- Take your HANDBIKE BATEC ELECTRIC to a distributor or technical service provider authorised by BATEC MOBILITY regularly for servicing.
- Avoid contact or proximity to fire, particularly lit cigarettes.
- If the HANDBIKE BATEC ELECTRIC is exposed to direct sunlight or low temperatures for an extended period of time, the HANDBIKE BATEC ELECTRIC pieces may overheat (>41°C) or become too cold (<0 °C).
- Only use our charger to charge the battery.
- If you don't use your HANDBIKE BATEC ELECTRIC for an extended period of time, make sure the battery is fully charged and recharge it every 2 months to avoid damage caused by "deep discharge".
- Keep the HANDBIKE BATEC ELECTRIC out of the reach of children when not under adult supervision.
- Do not open the battery, as there is a risk of explosion and/or fire. .

2.4. LIFESPAN

The BATEC ELECTRIC HANDBIKE has a lifespan of at least 5 years, as long as it is used according to the indicated operating conditions and receives proper maintenance and revisions, as indicated.

The life of the battery is between 200 and 500 charging cycles, and between 1 and 3 years, depending on several factors, including temperature, frequency of use, consistency of use and other individual issues (user weight, driving style, terrain, etc.).

3. MODELS: CHARACTERISTICS AND PARTS

i INFORMATION!

The Batecs shown and described in this manual may not be exactly the same as the model you own. However, all of the instructions provided here apply. The manufacturer reserves the right to modify the weights, measurements and other technical details in this manual without prior notice. All figures, measurements and capacities in this manual are approximate and not technical specifications. The manufacturer reserves the right to modify this manual without prior notice. The most current version of the manual is always available online: <https://support.batecmobility.com/en/support/>

There are four HANDBIKE BATEC ELECTRIC models: MINI 2, MINI, ELECTRIC 2 and SCRAMBLER (2018 platform). All of the HANDBIKE BATEC ELECTRIC models have the same anchoring system and the same type of structure, only wheel size, top speed and features:

- MINI 2: powered by an electric motor on the 12" front wheel. (See fig. 4a)
- MINI: powered by an electric motor on the 16" front wheel. (See fig. 4b)
- ELECTRIC 2: powered by an electric motor on the 18" front wheel. (See fig. 4c)
- SCRAMBLER: powered by an electric motor on the 19" front wheel (all terrain). (See fig. 4d)

All four HANDBIKE BATEC ELECTRIC models are designed for users with full hand function in their standard configuration. For users without full hand function, we have specially adapted controls, sold under the name QUAD. For users who only have functional difficulties in one

of their upper limbs, we offer controls specially adapted to this situation, sold under the name HEMI. More information in the box below.

i INFORMATION!

SKILLS NEEDED TO USE THE BATEC HANDBIKES: HANDBIKES BATEC are only recommended for people with the physical and psychological conditions to circulate in traffic. The standard HANDBIKE BATEC ELECTRIC models require full use of hands and arms.

To use the models with QUAD controls, users must have good arm function and partial hand function, enough to accelerate, brake and turn without danger. This is why BATEC MOBILITY always offers users the option to test the product before purchasing.

The most serious spinal cord injury compatible with use of the HAND-BIKE BATEC ELECTRIC QUAD is functional C6 (good biceps function and wrist motion is essential).

To use versions equipped with HEMI controls, users must have full functionality (hand and arm) in at least one of their upper limbs.

(See fig. 5)

3.1. HANDBIKE BATEC ELECTRIC MINI 2 / MINI / ELECTRIC 2 (RAPID 2) / SCRAMBLER

3.1.1. Characteristics

MINI 2

- Material: Aluminium 7005 T6/ Aluminium 6061 T6
- Motor: Brushless 350 W 350 RPM / Peak power: 600 W / Reverse gear
- Top speed: 20 km/h

- Battery: 2 battery options available:
 - 280 Wh (7.8 Ah) battery with 22-km battery life*
 - 522 Wh (14.5 Ah) battery with 40-km battery life*
- * Battery life calculated under the following conditions: 75-kg user, extra-light wheel-chair, flat terrain, no wind and steady speed of 15 km/h. May vary ± 20 % depending on the battery.
- Super-fast 4A charger
- The BATEC power and steering system has a V-0 flammability rating, according to UL94 standards.
- Tyre: 12" ultra-grip
- Rim: 12" double-wall aluminium
- Brakes: Avid BB5 140 mm mechanical disc brakes with aluminium levers and parking brake.
- Headset: 1.1/8 black
- Handlebar: Matte black aluminium
- BATEC EASY-FIT regulation system (Pat. Pend.)
- BATEC EASY-FIX anchor system (Pat. Pend.)
- BATEC SAFE-FEET stand frame (Pat. Pend.)
- 100 lumen front LED light, runs off main battery
- Dual LED tail light on the stand frame
- ALL-IN-ONE display panel (battery indicator, 3-speed selector and rear gear, cycle computer, front and rear lights, and horn, all with 4 buttons on the handlebar)
- Weight: 10.9 kg (without battery)
- Dimensions: (See fig. 6)

MINI

- Material: 7005 T6 aluminium
- Motor: 250 RPM, 900 W brushless motor / Nominal power: 900 W / Reverse gear
- Top speed: 20 km/h
- Battery (2 options available):
 - 280 Wh (7.8 Ah) battery with 22-km battery range*
 - 522 Wh (14.5 Ah) battery with 40-km battery range*
- * Battery range calculated under the following conditions: 75-kg user, extra-light wheel-chair, flat terrain, no wind and steady speed of 15 km/h. Life may vary ± 20 % depending on the battery.
- Fast 4A charger
- Tyre: 16" ultra-grip
- Rim: 16" double-wall aluminium
- Brakes: Avid BB5 180 mm mechanical disc brakes with aluminium levers and parking brake
- Headset: 1.1/8 black
- Handlebar: Black matte aluminium
- HANDBIKE BATEC ELECTRIC EASY-FIT regulation system
- HANDBIKE BATEC ELECTRIC EASY-FIX anchor system
- HANDBIKE BATEC ELECTRIC SAFE-FEET stand frame
- 700 lumen front LED light, runs off main battery
- Dual LED tail light on the stand frame
- ALL-IN-ONE LCD screen (battery gauge, 3-speed regulator and rear gear, cycle computer, front and rear lights, and horn, all with 4 buttons on the handlebar)
- Weight: 14.6 kg (without battery)
- Dimensions: (See fig. 7)

ELECTRIC 2

- Material: 7005 T6 aluminium
- Motor: 250 RPM, 900 W brushless motor / Nominal power: 900 W / Reverse gear
- Top speed: 25 km/h
- Battery (2 options available):
 - 280 Wh (7.8 Ah) battery with 22-km battery range*
 - 522 Wh (14.5 Ah) battery with 40-km battery range*
- * Battery range calculated under the following conditions: 75-kg user, extra-light wheel-chair, flat terrain, no wind and steady speed of 15 km/h. Life may vary $\pm 20\%$ depending on the battery.
- Fast 4A charger
- Tyre: 18" ultra-grip
- Rim: 18" double-wall aluminium
- Brakes: Avid BB5 180 mm mechanical disc brakes with aluminium levers and parking brake
- Headset: 1.1/8 black
- Handlebar: Black matte aluminium
- HANDBIKE BATEC ELECTRIC EASY-FIT regulation system
- HANDBIKE BATEC ELECTRIC EASY-FIX anchor system
- HANDBIKE BATEC ELECTRIC SAFE-FEET stand frame
- 700 lumen front LED light, runs off main battery
- Dual LED tail light on the stand frame
- ALL-IN-ONE LCD screen (battery gauge, 3-speed regulator and rear gear, cycle computer, front and rear lights, and horn, all with 4 but-tons on the handlebar)
- Removable weights

- Weight: 14.9 kg (without battery/weights)

- Dimensions: (See fig. 8)

RAPID 2

- Colour: graphite with red trim
- Top speed: 30 km/h
- Autonomy:
 - 22 km* with 280-Wh battery
 - 50 km* with 679-Wh battery
- * Autonomy calculated with: 75-kg user, ultra-light wheelchair, flat terrain, no wind and a steady speed of 15 km/h. May vary $\pm 20\%$ depending on the battery.
- Motor: 300-RPM brushless / Nominal power: 1200 W / Peak power: 1300 W
- Reverse gear
- Batteries with connector only suitable for use with the BATEC RAPID 2 and BATEC SCRAMBLER 48 V – 678 Wh
- Optional flight-safe battery 36/48 W – 280 Wh (can't be chosen as the main battery as it limits the performance of the BATEC RAPID 2 due to 36 V power).
- Fast 3A charger
- Chassis: Black aluminium 7005 T6 headset 1.1/8 Detachable dropout
- Matte black aluminium handlebar
- Avid BB7 mechanical brakes Avid Speed Dial brake levers. 180 mm Galfer Wave floating rotor disc
- Tyre: ultra-grip 18" x 2.40"
- Rim: 18" black double-wall aluminium
- 700-lm front light with running lamp. Dual LED tail light on the stand frame

- All-in-one LCD screen with cycle computer and battery gauge
- USB port Horn
- BATEC ACOPLA support
- Removable QR weights Scrambler BATEC ASA
- Weight 15.9 kg (without battery or weights)
- Dimensions:: (See fig. 9)

SCRAMBLER

- Material: 7005 T6 aluminium
 - Motor: 250 RPM, 900 W brushless motor / Nominal power: 1200 W / Reverse gear
 - Top speed: 30 km/h
 - Battery:
 - 679 Wh (14.5 Ah) battery with 50-km battery range*
- *Battery range calculated under the following conditions: 75-kg user, extra-light wheel-chair, flat terrain, no wind and steady speed of 15 km/h. Life may vary $\pm 20\%$ depending on the battery.
- Fast 3A charger
 - Tyre: 19" ultra-grip
 - Rim: 19" double-wall aluminium
 - Brakes: Hydraulic double TRP HY/RD brake with adjustable Avid Speed Dial Titanium brake levers
 - Headset: 1.1/8 FSA Orbit Mx black
 - Handlebar: Ultra-wide aluminium
 - HANDBIKE BATEC ELECTRIC EASY-FIT regulation system
 - HANDBIKE BATEC ELECTRIC EASY-FIX anchor system

- Stand frame with suspension
- 700 lumen front LED light, runs off main battery
- Dual LED tail light on the stand frame
- ALL-IN-ONE LCD screen (battery gauge, 3-speed regulator and rear gear, cycle computer, front and rear lights, and horn, all with 4 but-tons on the handlebar)
- Removable weights
- Weight: 16.1 kg (without battery/weights)
- Dimensions: (See fig. 10)

3.1.2. Parts of the HANDBIKE BATEC ELECTRIC MINI 2 / MINI / ELECTRIC 2 (RAPID 2) / SCRAMBLER (See fig.11a, 11b, 11c, 11d, 11e, 11f, 11g)

3.1.3. Parts of the HANDBIKE BATEC ELECTRIC QUAD MINI 2 / MINI / ELECTRIC 2 (RAPID 2) / SCRAMBLER (See fig.12)

3.1.4. Parts of the HEMI control for the HANDBIKE BATEC ELECTRIC MINI 2 / MINI / ELECTRIC 2 (RAPID 2) / SCRAMBLER (See fig.13)

A left-handed version is also available with symmetrical controls regarding the one displayed.

4. OPERATING THE HANDBIKE BATEC ELECTRIC / USER GUIDE

4.1. DELIVERY

Your new HANDBIKE BATEC ELECTRIC will be delivered in a cardboard box. In order to prevent damage during transport, parts that must be assembled later, like the battery, are packaged separately inside the cardboard box.

4.2. UNPACKING

- Check that the outside of the cardboard box hasn't been damaged in any way during transport.
- Remove all of the packing materials.
- Remove the parts of the HANDBIKE BATEC ELECTRIC (including the battery and charger) from the cardboard box and check that they are all there.
- Check that all the parts are in proper conditions, without any sort of damage, scratches, tears, dents, irregularities or other defects.
- If you find any problems, or if any pieces are missing, notify the authorised distributor immediately.

4.3. ELEVATION, TRANSPORT AND STORAGE

The HANDBIKE BATEC ELECTRIC has been designed so that users can easily remove and detach the battery on their own.

- When taking the HANDBIKE BATEC ELECTRIC on any means of transport (car, bus, train, plane, etc.), we recommend removing the battery before your journey: turn the battery key to OPEN, remove the key and then remove the battery.

- When lifting the HANDBIKE BATEC ELECTRIC, we recommend removing the weight as indicated in section 3.10 and the battery as per section 4.9.1.
- When transporting the HANDBIKE BATEC ELECTRIC in the boot of a vehicle, we recommend leaving it attached to a wheelchair whenever possible.

The BATEC HANDBIKE is not designed to be used as a means of transport inside a vehicle.

The HANDBIKE BATEC ELECTRIC ELECTRIC should be stored in a cool, dry place, protected from direct sunlight and rain. It should not be kept out of use for more than two months.

4.4. ATTACHING THE HANDBIKE BATEC ELECTRIC:

- Step 1: Get in front of the HANDBIKE BATEC ELECTRIC, with the handlebar centred in front of the wheelchair, with the brake on. (See fig. 14a, 14b)
- Step 2: Grab the HANDBIKE BATEC ELECTRIC by the handlebar and pull it towards you, rolling the frame stand until the detaching ramp on the anchoring bar touches the front axle of the bar on the wheelchair. (See fig. 15)
- Step 3: Tip the handlebar, lifting the front wheel, while pulling the HANDBIKE BATEC ELECTRIC towards you. When the detaching ramp has passed the front axle of the bar on the wheelchair, let go of the handlebar and put the front wheel back on the ground. (See fig. 16a, 16b)
- Step 4: Take off the brake on the wheelchair and push gently on the HANDBIKE BATEC ELECTRIC handlebar to make sure the front axle is securely in place.
- Step 5: Push the handle until it clicks, so that both the wheels on the HANDBIKE BATEC ELECTRIC stand frame and the front wheels on the wheelchair are off the ground. Your HANDBIKE BATEC ELECTRIC is now attached. (See fig. 17)

4.5. DETACHING THE HANDBIKE BATEC ELECTRIC

- Step 1: Make sure your HANDBIKE BATEC ELECTRIC is switched off. (See fig. 18)
- Step 2: Push the anchor lever forward with the palm of your hand until you feel it come free. Don't let go of the lever and set the HAND-BIKE BATEC ELECTRIC on the ground. Advice: lean your torso back to take weight off the lever. This will make it much easier to detach the HANDBIKE BATEC ELECTRIC. (See fig. 19)
- Step 3: Tilt the handlebar, lifting the front wheel, while you push the HANDBIKE BATEC ELECTRIC away from you. (See fig. 20)
- Step 4: When the detaching ramp has gone over the front axle of the wheelchair bar, let go of the handlebar and set the front wheel down again. Your HANDBIKE BATEC ELECTRIC is now detached. (See fig. 21)



ADVICE!

Practice attaching and detaching your HANDBIKE BATEC ELECTRIC calmly and you'll see that, in just a few weeks of use, it will become automatic.

.....

4.6. USING THE HANDBIKE BATEC ELECTRIC MINI 2 / MINI / ELECTRIC 2 (RAPID 2) / SCRAMBLER CONTROLS

- You can find out the meaning of all the symbols used on the controls of the BATEC ELECTRIC HANDBIKE in Figure 58.
- Turn on: Turn the key on the right side of the battery clockwise to the ON position. It will do a system check: don't start using your HAND-BIKE BATEC ELECTRIC until it has finished with the system check and all the lights are on. (See fig. 22)
- Turn off: Turn the key on the battery anti-clockwise to the OFF po-

sition. If you leave it in the OPEN position, your HANDBIKE BATEC ELECTRIC will be off and the battery will be ready to remove. (See fig. 22)

- Speed up: The throttle is on the right grip on the handlebar. It works just like a motorbike, meaning you can regulate your speed by turn-ing the throttle on the grip. (See fig. 23)
- Brake: The HANDBIKE BATEC ELECTRIC has two brake levers on the handlebar that activate the disc brakes. Squeeze the lever to activate the brakes. Advice: Use one hand to accelerate and the other to brake. Advice: Always keep two fingers on the brake lever in order to respond quickly. Pressing on the brake lever and the red lever at the same time blocks the brake lever, acting as a parking brake. (See fig. 24)
- Moving forwards and backwards and limiting speed:
 - Press the F button to move forwards.
 - Press it again to select the 3 speed limits, successively..
 - Press the R button to move backwards.
 - This is only possible if the HANDBIKE BATEC ELECTRIC is stopped and the throttle not engaged. (See fig. 25)
- Lights: There is a button on the HANDBIKE BATEC ELECTRIC handle-bar to switch on the front and rear lights. When you push the button, the front light will go on in normal mode and the light indicator on the display panel will turn green. When you push the front light button again, it changes to high-beam mode, and so on. To turn off the lights, hold the button down for 2 seconds. The front light is below the battery and the two rear lights, on either side of the stand frame. (See fig. 26a, 26b, 26c)

4.7. USING THE HANDBIKE BATEC ELECTRIC QUAD MINI 2 / MINI / ELECTRIC 2 (RAPID 2) / SCRAMBLER CONTROLS

- You can find out the meaning of all the symbols used on the controls of the BATEC ELECTRIC HANDBIKE in Figure 58.

- Turn on: Turn the key on the right side of the battery clockwise to the ON position. It will do a system check: don't start using your HAND-BIKE BATEC ELECTRIC until it has finished with the system check and all the lights are on. (See fig. 27)
- Turn off: Turn the key on the battery anti-clockwise to the OFF position. If you leave it in the OPEN position, your HANDBIKE BATEC ELECTRIC will be off and the battery will be ready to remove. (See fig. 27)
- Speed up: Pull the HANDBIKE BATEC ELECTRIC QUAD MINI handle-bar towards you to activate the throttle. (See fig. 28)
- Brake: Push the HANDBIKE BATEC ELECTRIC QUAD MINI handlebar away from you to activate the brake. (See fig. 29)
- Moving forwards and backwards and limiting speed (See fig. 30):
 - Press the F button to move forwards.
 - Press it again to select the 3 speed limits, successively.
 - Press the R button to move backwards.
 - This is only possible if the HANDBIKE BATEC ELECTRIC is stopped and the throttle not engaged.
- Lights: There is a button on the HANDBIKE BATEC ELECTRIC handle-bar to switch on the front and rear lights. When you push the button, the front light will go on in normal mode and the light indicator on the display panel will turn green. When you push the front light button again, it changes to high-beam mode, and so on. To turn off the lights, hold the button down for 2 seconds. The front light is below the battery and the two rear lights, on either side of the stand frame. (See fig. 31a, 31b, 31c)

4.8. OPERATING THE HANDBIKE BATEC ELECTRIC MINI 2 / MINI / ELECTRIC 2 (RAPID 2) / SCRAMBLER HEMI CONTROLS

- You can find out the meaning of all the symbols used on the controls of the BATEC ELECTRIC HANDBIKE in Figure 58.

- Turn on: Turn the key on the right side of the battery clockwise to the ON position. It will do a system check: don't start using your HAND-BIKE BATEC ELECTRIC until it has finished with the system check and all the lights are on. (See fig. 32)
- Turn off: Turn the key on the battery anti-clockwise to the OFF position. If you leave it in the OPEN position, your HANDBIKE BATEC ELECTRIC will be off and the battery will be ready to remove. (See fig. 32)
- Speed up: The throttle is on the right or left grip on the handlebar. (See fig. 33)
- Brake: Pressing on the brake lever and the red lever at the same time blocks the brake lever, acting as a parking brake. (See fig. 34)
 - Moving forwards and backwards and limiting speed: (See fig. 35):
 - Press the F button to move forwards.
 - Press it again to select the 3 speed limits, successively.
 - Press the R button to move backwards.
 - This is only possible if the HANDBIKE BATEC ELECTRIC is stopped and the throttle not engaged.
- Lights: There is a button on the HANDBIKE BATEC ELECTRIC handlebar to switch on the front and rear lights. When you push the button, the front light will go on in normal mode and the light indicator on the display panel will turn green. When you push the front light button again, it changes to high-beam mode, and so on. To turn off the lights, hold the button down for 2 seconds. The front light is below the battery and the two rear lights, on either side of the stand frame. (See fig. 36a, 36b, 36c)

4.9. BATTERY

BATEC MOBILITY offers 2 36-V lithium-ion batteries: 280 Wh and 522 Wh, respectively and 1 48 V 679 Wh lithium-ion battery. Each without memory effect and with a cable-free connection system.

THE 280 WH BATTERY COMPLIES WITH IATA-DGR REGULATIONS for air travel with batteries in mobility-aid devices. (See fig. 37)

Lithium ion batteries have many advantages over other batteries, mainly due to their flexibility. They don't have to be completely charged every time they are used, nor do they have to be used continuously or fully drained each time.

BATEC MOBILITY only uses batteries with the safest technology available, including the BMS smart battery management system.

4.9.1 BASIC BATTERY USE

Inserting and removing the HANDBIKE BATEC ELECTRIC battery

You don't need to touch any connectors to insert or remove the battery from your HANDBIKE BATEC ELECTRIC, as this is done automatically.

(See fig. 38)

- To remove the battery: Turn the key to the REMOVE BATTERY position (OPEN). Grab the handle of the battery and pull up gently until the battery comes fully of the guide. (See fig. 39)
- To insert: Grab the battery by the handle. Set the lower right corner of the battery in the side support tab until it clicks into the guide. Slide the battery down slowly until it is resting completely in the mount. (See fig. 40)

.....

 **IMPORTANT!**

If you leave the battery in the OFF AND REMOVE KEY WITH DETACHING LOCK position (OFF), you won't be able to remove it.

.....

Connecting the battery:

To connect the HANDBIKE BATEC ELECTRIC battery, simply turn the key to the ON position and use your HANDBIKE BATEC ELECTRIC normally.

(See fig. 41)

The battery charging system is protected by the smart battery management system (BMS), which cuts power if there is a surge or if any of the battery cells are too discharged. (See fig. 42)

.....

 **CAREFUL!**

Never, under any circumstances, use the discharging port on the battery to charge it or power it in any way, whether with an external power source or regenerative brake system.

.....

Charging the battery:

- The HANDBIKE BATEC ELECTRIC battery is charged with the 3-pin XLR port on the side of the battery. (See fig. 43)
- Only charge the battery with the original BATEC MOBILITY charger provided with your HANDBIKE BATEC ELECTRIC.

.....

 **CAREFUL!**

Never, under any circumstances, use chargers from other manufacturers or a charger from another HANDBIKE BATEC ELECTRIC, as the specifications for each HANDBIKE BATEC ELECTRIC series are different.

.....

- Recharge time for the BATEC MOBILITY battery is 3 hours. Both the charger and the battery management system cut the power when the battery is fully charged.
- Charging the battery: To charge the battery, the key must be in the OFF or OPEN position. You can charge the battery whether or not it is attached to the HANDBIKE BATEC ELECTRIC. Turn the cover of the charging port, plug the charger first into the port and then into a socket, then turn the charger on.

Storing the battery

Lithium ion batteries have a smart battery management system (BMS) that uses a small amount of power to monitor the battery at all times. The amount used is very small but if you store the battery fully dis-charged, in just a few weeks the BMS can run out of power.

If this happens, the battery can never be used again. As a result, we strongly recommend you follow these instructions carefully:



CAREFUL!

- Charge the battery fully before storing it.
- Always store the battery with the key in the OFF position.
- Charge the battery fully at least every 2 months.
- If the battery doesn't work after being stored for a period of time, for your safety it must be disposed of. .

4.9.2. BATTERY SAFETY INFORMATION

It is widely known that lithium ion batteries can be dangerous, and for good reason. Batteries used in vehicles, like those in the Batecs, have enough stored energy and potentially dangerous material to cause a significant incident if not used properly or in the case of negligence.

BATEC MOBILITY ONLY USES LITHIUM BATTERY TECHNOLOGY IT CONSIDERS STABLE AND SAFE.

All BATEC MOBILITY batteries use safety systems, including the smart battery management system (BMS), which monitors the battery at all times.

In addition to all of the built-in safety systems, to minimise the danger if a problem were to arise with elements outside the battery, such as improper functioning of the electrical installations or problems with

the general power grid, we strongly recommend you follow these instructions carefully:



CAREFUL!

- Only charge the battery under supervision.
- Don't charge the battery while using your BATEC ELECTRIC HAND-BIKE: Danger of electrocution and accidents.
- Don't charge the battery while asleep at night.
- Charge the battery well away from any flammable objects.
- Never use the discharging port to charge the battery and vice versa, never use the charging port to discharge it.
- Only use the BATEC MOBILITY charger provided with your HANDBIKE BATEC ELECTRIC to charge the battery.
- Never charge the battery near a heat source.
- Never charge the battery in temperatures below 0°C.
- Always store the battery fully charged.
- Don't allow the inside of the battery to be manipulated in any way, as there is a risk of explosion and/or fire.

4.9.3. ADDITIONAL INFORMATION ON THE BATTERY

Using the battery in cold conditions

The performance of lithium batteries is limited, both in terms of power and battery life, in low temperatures (below 0°C). It isn't a dangerous situation but it is bothersome, so we recommend storing the battery inside under these circumstances. Never charge the battery in temperatures below 0°C.

Using the battery in damp conditions

The casing of the BATEC MOBILITY battery provides good protection against rain and dampness for the cells and circuits inside. This protection is enough for the battery to withstand these conditions occasionally but regular, prolonged exposure to damp and rainy conditions may cause the battery to stop working properly. Thus, we recommend you avoid these circumstances and use the HANDBIKE BATEC ELECTRIC as little as possible in rainy or snowy conditions.

Battery life

The life of the battery is between 200 and 500 charging cycles, and between 1 and 3 years, depending on several factors, including temperature, frequency of use, consistency of use and other individual issues (user weight, driving style, terrain, etc.).

To get the most out of your battery we recommend you:

IMPORTANT!

- Drive gently at moderate speeds.
- Avoid exposure to high temperatures.
- Avoid exposure to low temperatures (below 0°C).
- Avoid leaving the battery unused for long periods of time.

The battery won't just die suddenly; it gradually begins to perform more poorly. If your battery suddenly stops working, it is normally due to a technical problem and not the end of its lifespan.

Disposing of the battery

As with all batteries, the BATEC MOBILITY batteries must be disposed

of properly. Check with your local waste-management centre. Contact BATEC MOBILITY if you have any doubts.

Battery indicator operation

The battery status indicator is on the display (LCD panel) of the BATEC ELECTRIC HANDBIKE. The indicator is made up of several bars that indicate the % of energy available. (See fig. 59)

4.9.4. TECHNICAL SPECIFICATIONS OF THE 280 WH BATTERY

- Dimensions: 350 x 140 x 60 mm
- Weight: 2.6 kg
- Power: 280 Wh
- Voltage: 36 V
- Maximum discharge current: 29 A
- Maximum charge current: 5 A
- Internal resistance: 200 mOhm
- BMS consumption: < 0.2 mA when on; < 0.02 mA when off
- Battery range by model:
 - HANDBIKE BATEC ELECTRIC MINI 2 / MINI / ELECTRIC 2 / RAPID 2 / SCRAMBLER: 22 km*

4.9.5. TECHNICAL SPECIFICATIONS OF THE 522 WH BATTERY

- Dimensions: 350 x 140 x 60 mm
- Weight: 4 kg
- Power: 522 Wh
- Voltage: 36 V
- Maximum discharge current: 29 A

- Maximum charge current: 5 A
- Internal resistance: 200 mOhm
- BMS consumption: < 0.2 mA when on; < 0.02 mA when off
- Battery range by model:
 - HANDBIKE BATEC ELECTRIC MINI 2 / MINI / ELECTRIC 2: 40 km*

4.9.6. SPECIFICATIONS OF THE 679 WH BATTERY

- Dimensions: 350 x 140 x 60 mm
- Weight: 4.6 kg
- Power: 679 Wh
- Battery: Panasonic PF 2.9 Ah
- Nominal voltage: 46.8 V
- Nominal charge: 14.5 Ah
- Maximum discharge current: 25 A
- Maximum charge current: 5 A
- Battery range by model HANDBIKE BATEC ELECTRIC SCRAMBLER /RAPID 2: 50 km*

* Battery range calculated under the following conditions: 75-kg user, extra-light wheel-chair, flat terrain, no wind and steady speed of 15 km/h. Range may vary ± 20 % depending on the battery.

4.10. WEIGHTS

Some HANDBIKE BATEC ELECTRIC models are equipped with standard weights to improve traction. The weights are located on the fork, one on each side. They each weigh 2.4 kg. To make it easier to transport the HANDBIKE BATEC ELECTRIC, the weights can be removed.

- To remove the weights:

- 1) Hold the weight with one hand, press on the red button, tilting it so the bottom part comes away from the HANDBIKE BATEC ELECTRIC. (See fig. 44)
- 2) Remove the weight. (See fig. 45)

- To insert the weights:

- 1) Hold the weight with one hand. Tilt it slightly and insert the two tabs into the weight mount slot. (See fig. 46)
- 2) Push the bottom of the weight inward until it clicks into place. (See fig. 47)

5. INSTALLATION AND ADJUSTMENTS

5.1. INSTALLATION OF THE HANDBIKE BATEC ELECTRIC ON A WHEELCHAIR

To anchor a HANDBIKE BATEC ELECTRIC to a wheelchair, you must first install a BATEC DOCKING-BAR (pat. pending). The BATEC DOCKING-BAR can be installed on most wheelchairs on the market, whether fixed or folding frame.

.....

IMPORTANT!

An updated list of wheelchairs compatible with the HANDBIKE BATEC ELECTRIC is available in the support section of the BATEC MOBILITY website.

.....

The HANDBIKE BATEC ELECTRIC must be installed on a wheelchair by a qualified professional authorised by BATEC MOBILITY. Contact BATEC MOBILITY to find the authorised installation professional closest to you.

5.2. USER ADJUSTMENTS

Once the HANDBIKE BATEC ELECTRIC is properly installed on the wheelchair, there are several adjustments that must be made in order to fit the HANDBIKE BATEC ELECTRIC to the user's level of mobility, type of disability and size.

These adjustments can be done easily with the tools and instructions provided with the HANDBIKE BATEC ELECTRIC and basic mechanical knowledge.

The following adjustments can be made:

- Adjusting the distance between the HANDBIKE BATEC ELECTRIC and the wheelchair.
- Adjusting the angle of the stem on the HANDBIKE BATEC ELECTRIC.
- Adjusting the height of the handlebar on the HANDBIKE BATEC ELECTRIC.

5.2.1. ADJUST THE DISTANCE BETWEEN THE HANDBIKE BATEC ELECTRIC AND THE CHAIR

With the HANDBIKE BATEC ELECTRIC anchored, adjust the distance between the HANDBIKE BATEC ELECTRIC and the wheelchair so that there is as little space as possible between the user's feet and the stand frame, using the telescopic anchoring bar and the screws indicated. If the user doesn't have any other preference or limitations, we recommend a distance of 8 cm. (See fig. 48)

5.2.2. ADJUST STEM ANGLE (EXCEPT MINI 2 MODEL)

With the HANDBIKE BATEC ELECTRIC anchored, adjust the angle of the stem on the HANDBIKE BATEC ELECTRIC in order to fit the handlebar to the user's arm length, using the screws indicated. The upper and lower screws must be set on the same number. If the user doesn't have any other preference or limitations, we recommend position 3. (See fig. 49)

5.2.3. ADJUST STEM HEIGHT

With the HANDBIKE BATEC ELECTRIC anchored, adjust the stem height on the HANDBIKE BATEC ELECTRIC with the Quick Release lever. (See fig. 50)

5.2.4. LCD CONSOLE ADJUSTMENTS

1. Switch on the battery to see the INFORMATION SCREEN. (See fig. 51)

2. Press M (mode) button to move between all functions in loop sequence from one function screen to another as CLOCK / ODO (odometer) - RT (partial time) / TT (total time) - AVG (average speed) / MAX (maximum speed) - TRIP 1 / ODO - TRIP 2 / ODO. (See fig. 52)
 - Press R (reset) button for 2 seconds to reset TRIP 2, AVG and MAX from stored values to zero individually.
 - Data of TRIP 1, AVG and RT can be reset at the same time when one of the three data functions is being reset.
 - ODO, CLOCK and TT data cannot be reset.
3. Press M and R buttons simultaneously for 2 seconds to display the SETTING SCREEN 1. (See fig. 53)
4. Press M button to move between all functions in loop sequence from one function screen to another as 12/24 hour, clock, circumference wheel number and Km/h or MPH.
 - Press R button to increment the flashing digit by 1 or convert units.
 - Press M button to confirm the digit setting and jump to next digit or next setting screen to be set.
 - The c (circumference number) values are those:
 - HANDBIKE BATEC ELECTRIC Mini 2: 947
 - HANDBIKE BATEC ELECTRIC Mini: 1288
 - HANDBIKE BATEC ELECTRIC Electric 2: 1445
 - HANDBIKE BATEC ELECTRIC Scrambler: 1621
 - Press M for 2 seconds at any setting screen to finish the setting and go to INFORMATION SCREEN
5. On SETTING SCREEN 1 (step 4) pressing M and R buttons simultaneously for 2 seconds will display the SETTING SCREEN 2. (See fig. 54)
 - Battery voltage value is on the bottom and manufacturer fine adjustment battery value is on top.
6. To return to INFORMATION SCREEN and fix all settings press M button for 2 seconds, if the screen displays SETTING SCREEN 1 press M button for 2 seconds again. (See fig. 55)

 **IMPORTANT!**

- Do not change the battery voltage value and fine adjustment battery value.
 - Don't exit SETTING SCREEN 1 by switching off the battery.
 - If the battery is fully charged and the screen display shows the following when switching on, you must follow steps 3, 5 and 6. (See fig. 56)
-

6. MAINTENANCE AND REPAIRS

Your HANDBIKE BATEC ELECTRIC has been carefully designed for optimal performance, but it is important that you carry out certain preventative maintenance tasks in line with the use you give your HAND-BIKE BATEC ELECTRIC. This will greatly reduce the chance of problems and increase the lifespan of your HANDBIKE BATEC ELECTRIC.

In order to minimise the risk of accidents and/or damage to your HANDBIKE BATEC ELECTRIC, it is very important to have all repairs carried out by an authorised BATEC MOBILITY distributor.

Remember that your main source of information and help is the distributor that delivered your HANDBIKE BATEC ELECTRIC, who can also respond to any questions regarding adjustments, maintenance and the warranty.

As you are a member of the "BATEC MOBILITY Family", we encourage you to stay in touch with your BATEC HANDBIKE representative in order to make the most of the product.

We propose the following preventative maintenance plan schedule:

PREVENTATIVE MAINTENANCE PLAN SCHEDULE

TO BE CHECKED	6months 500 km	1 year 1000 km	1.5 years 1500 km	2 years 2000 km	2.5 years 2500 km
Frame tube torque (18 nm)	✓		✓		✓
Steering angle regulator torque (18 nm)	✓		✓		✓
Anchoring bar torque (8 nm)	✓		✓		✓
Hub motor torque (40 nm)	✓	✓	✓	✓	✓
BATEC DOCKING BAR	✓	✓	✓	✓	✓
Thickness (minimum 1 mm) brake pads	✓	✓	✓	✓	✓
Break cable and cover	✓		✓		✓
Gear-shift cable and cover	✓		✓		✓
Gear shifter	✓		✓		✓
Chain	✓		✓		✓
Tyre pressure (bar according to model) and treads (≥ 1 mm)	✓	✓	✓	✓	✓

PREVENTATIVE MAINTENANCE PLAN SCHEDULE

TO BE CHECKED	3 years 3000 km	3.5 years 3500 km	4 years 4000 km	4.5 years 4500 km	5 years 5000 km
Frame tube torque (18 nm)		✓		✓	
Steering angle regulator torque (18 nm)		✓		✓	
Anchoring bar torque (8 nm)		✓		✓	
Hub motor torque (40 nm)	✓	✓	✓	✓	✓
BATEC DOCKING BAR	✓	✓	✓	✓	✓
Thickness (minimum 1 mm) brake pads	✓	✓	✓	✓	✓
Break cable and cover		✓		✓	
Gear-shift cable and cover		✓		✓	
Gear shifter		✓		✓	
Chain		✓		✓	
Tyre pressure (bar according to model) and treads (≥ 1 mm)	✓	✓	✓	✓	✓

Checking tyre pressure:

Make sure the tyre pressure is as recommended for each model and that there are no irregularities on the surface.

Cleaning the HANDBIKE BATEC ELECTRIC:

Clean the frame with soap and warm water. Use car soap or another non-abrasive cleaning agent. Dry it carefully. Never use a pressure washer to clean it.

.....
 **IMPORTANT!**

Sand and salt water can damage some parts of the HANDBIKE BATEC ELECTRIC after prolonged contact. Clean it after use in these conditions.

.....

Cleaning front and rear wheels:

Make sure the front wheel and rear wheels turn freely and eliminate any dirt.

Checking brakes:

Make sure that when you squeeze the brake levers, both have sufficient contact with the disc for effective braking.

Greasing cables and chains:

Apply a drop of grease or light coat of Teflon spray to the cable connecting levers and to chains, after removing the old grease. After applying, remove any excess grease.

Greasing the transmission mechanism:

Apply a drop of grease or light coat of Teflon spray to the transmission mechanism, after removing the old grease. After applying, remove any excess grease.

Having HANDBIKE BATEC ELECTRIC serviced by an authorised distributor:

The recommended preventive maintenance and any repairs to your BATEC ELECTRIC HANDBIKE must be done by a company authorised by BATEC MOBILITY.

Replacing tyres and inner tubes:

Before installing a new inner tube, check the base of the rim and in-side wall of the tyre to remove any foreign bodies and, if necessary, clean well. Check the conditions of the rim tape, particularly around the valve hole. Only strong, properly placed rim tape can provide long-term protection against damage to the inner tube caused by burrs and sharp spoke heads.

Before inflating the inner tube, check the whole tube to make sure it hasn't got stuck between the tyre and the rim. Carefully pull on the valve and extract it for optimal installation.

CAREFUL!

After installing the new inner tube, check tyre pressure. It is essential to keep pressure at specified levels and to make sure tyres are in proper conditions in order to ensure your personal safety and keep your HANDBIKE BATEC ELECTRIC in proper working order.

IMPORTANT!

As the necessary maintenance varies between users, check with your BATEC MOBILITY representative to establish a periodic maintenance schedule that fits your specific use.







IMPORTANT!

Always do a safety check of your HANDBIKE BATEC ELECTRIC before using. Improper maintenance may invalidate the warranty.

7. LABEL

All BATEC ELECTRIC HANDBIKES have a label on the bottom of the frame bar with the following information: (See fig. 57)

SYMBOLS:

	Manufacturer
SN	Serial number
REF	Catalogue number
	This product complies with the requirements of Regulation (EU) 2017/745 on medical devices
	Date manufactured
	See user instructions
MD	With the text "Medical Device"
	Check warnings (battery)
	EN 12184:2014 – Wheelchair not intended for use as a seat in a motor vehicle
	ISO 7000 – Maximum weight allowed

When ordering spare parts or lodging claims, please provide the information on the label.

8. WARRANTY

8.1. WARRANTY PERIOD

BATEC MOBILITY guarantees all hard and structural parts for a period of two (2) years from the date of delivery in the case of material defects or labour for the original registered owner.

BATEC MOBILITY guarantees the BATTERY for a period of one (1) year from the date of delivery in the case of material defects or labour for the original registered owner. The BATTERY is considered a fungible part.

8.2. WARRANTY CONDITIONS

- Fungibles (except for the BATTERY, which has a one-year warranty) are excluded from the warranty, except in the case of premature wear on said parts caused by original manufacturing defects. These elements include tyres, inner tubes, handles, cables for brakes, gear shifter and anchoring, stand frame wheels and similar parts.
- If you have any questions regarding the warranty, BATEC MOBILITY recommends first contacting your authorised BATEC MOBILITY distributor, who will explain the solutions available for the problem.
- BATEC MOBILITY shall not be held responsible for any defects that may arise as a result of improper use or storage of the HANDBIKE BATEC ELECTRIC. If BATEC MOBILITY considers that a part has not been properly installed, used or stored, the warranty will be invalidated. Some examples are as follows:
 - The product or part hasn't been maintained according to BATEC MOBILITY recommendations, as detailed in the user instructions and maintenance instructions.
 - Non-original accessories have been used.

- The HANDBIKE BATEC ELECTRIC or its parts have been damaged due to negligence, accident or improper use.
- The HANDBIKE BATEC ELECTRIC or its parts have been modified in a way that is not in line with BATEC MOBILITY specifications or have undergone repairs without notifying the authorised distributor or technical service provider.
- BATEC MOBILITY reserves the right, with any claim, to require the claimant to send all parts to BATEC MOBILITY for replacement or re-pair at their own cost. If any of the parts are found to be defective, BATEC MOBILITY will determine whether to replace, repair or main-tain the parts.
- This warranty doesn't include transport, shipping or labour costs for removing and reinstalling the parts. BATEC MOBILITY will charge the claimant for any costs incurred if the parts are found not to be de-fective or the damage has been caused by events not covered under this warranty.
- Defective parts will be repaired or replaced exclusively by BATEC MO-BILITY or a duly qualified official BATEC MOBILITY service provider.
- BATEC MOBILITY doesn't ensure any of its products or parts will be available on the market or suitable for any particular purpose and provides no guarantee, express or implied, beyond the attached lim-ited warranty.
- Replacement parts installed during the original warranty period shall have an additional 2-year warranty. For the BATTERY, as it is considered a fungible part, the replacement unit shall be under warranty for the remaining warranty period on the original BAT-TERY, up to 1 year from the date the HANDBIKE BATEC ELECTRIC was delivered.
- This warranty is non-transferable: This warranty is only valid for the original registered user, who must provide the original receipt as proof of purchase.

- BATEC MOBILITY shall not be held responsible for any products not purchased at the recommended retail price.
- Except where prohibited by law, this limited warranty constitutes the full agreement between the owner and BATEC MOBILITY regarding any sort of liability that may arise concerning any parts on the HAND-BIKE BATEC ELECTRIC products.
- BATEC MOBILITY and the competent authority in the Member State of residence should be notified of any serious incidents related to the use of the product.

8.3. WARRANTY CARD

With the rest of the documentation for your HANDBIKE BATEC ELEC-TRIC, you will find a Warranty Card with all the details regarding your HANDBIKE BATEC ELECTRIC. You can use this card to provide all the details of your HANDBIKE BATEC ELECTRIC if a situation arises that requires the warranty.

9. REVISIONS LIST

Version	Summary / justification of changes
1.0	To adapt to the requirements of Regulation (EU) 2017/745

HANDBIKE BATEC ELECTRIC

- MINI 2
- MINI
- ELECTRIC 2 (RAPID 2)
- SCRAMBLER

FIGURES

FIG

FIGURES

1



Between buttons

2



In adjustment slots

3

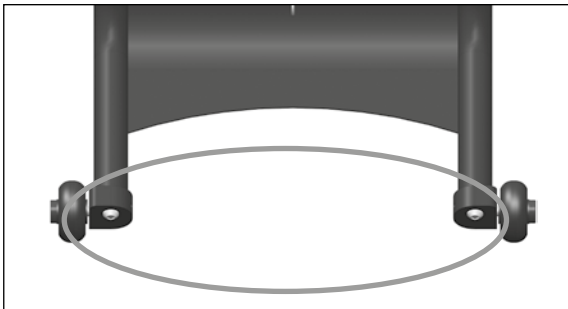

Between the product support structure (installed on the wheelchair) and the ground

4

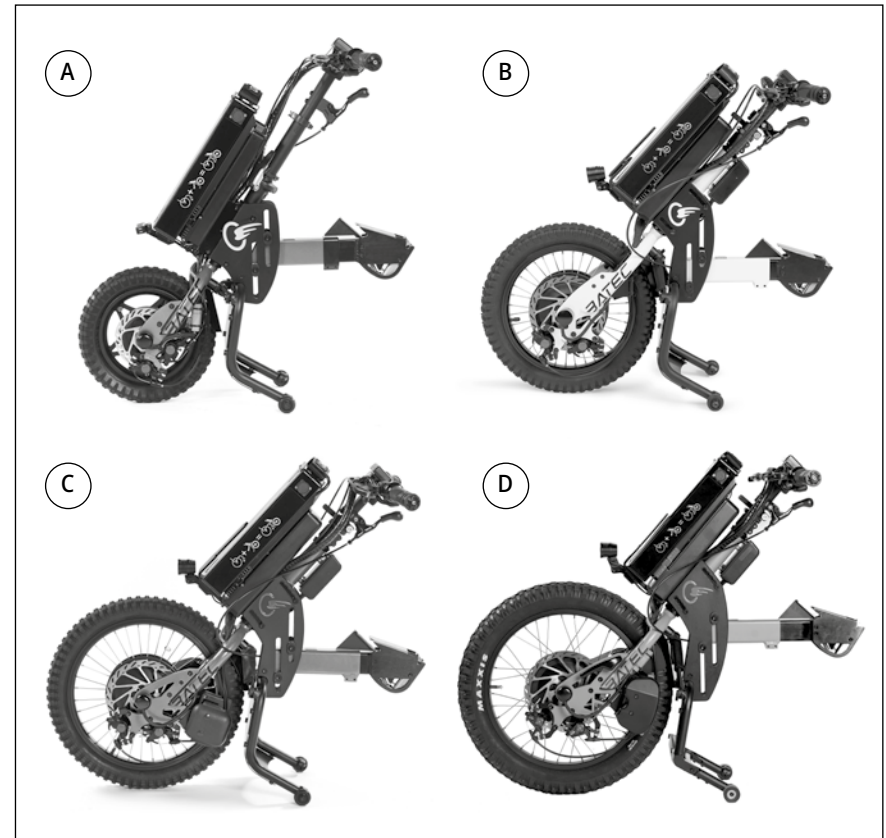

5

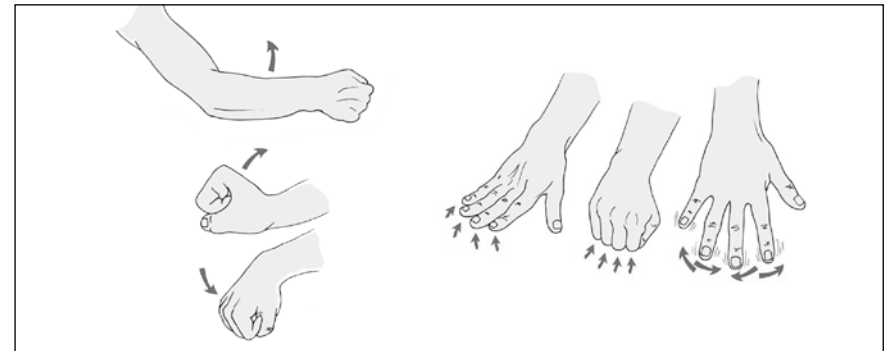

6a

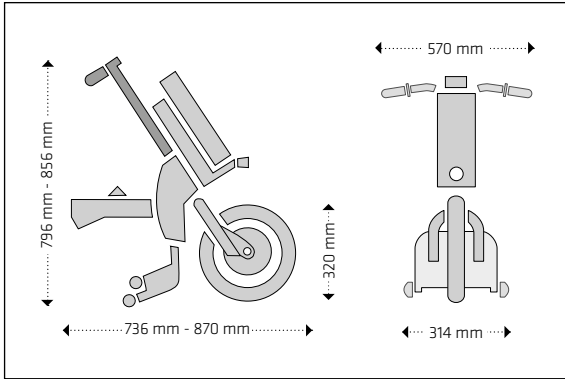

HANDBIKE BATEC
MINI 2 dimensions
folded out

8

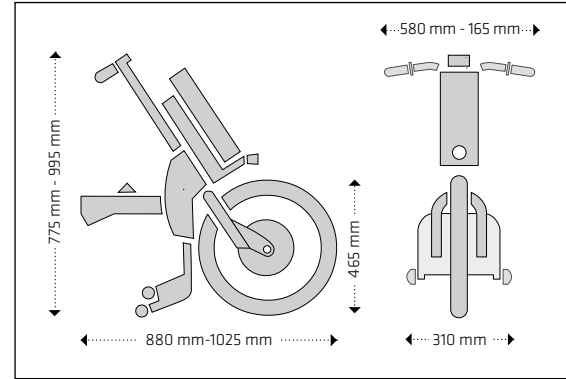

HANDBIKE BATEC
ELECTRIC 2 dimensions

6b

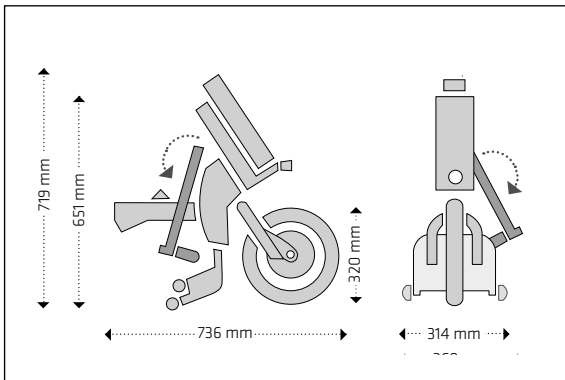

HANDBIKE BATEC
MINI 2 dimensions
folded in

9

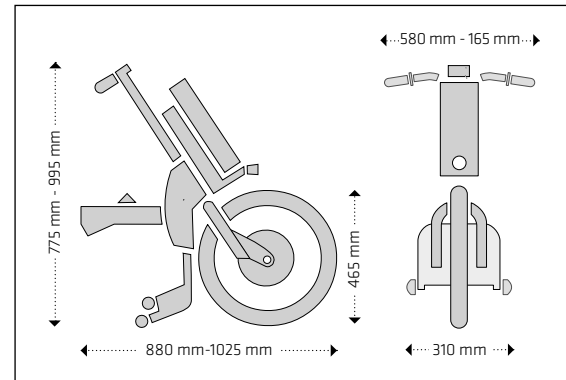

HANDBIKE BATEC
RAPID 2 dimensions

7

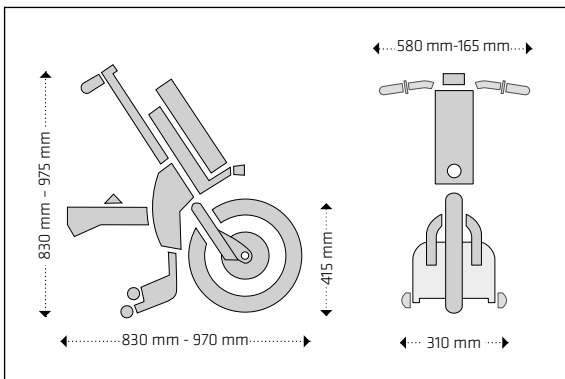

HANDBIKE BATEC
MINI dimensions

10

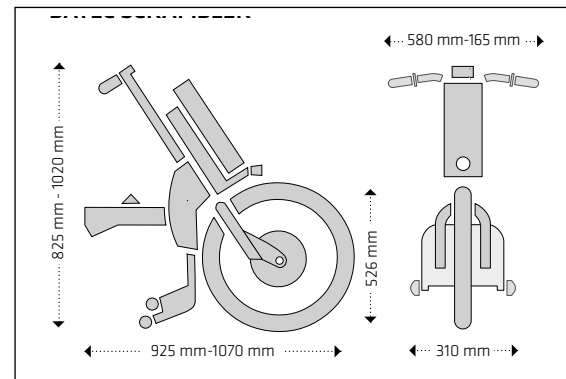

HANDBIKE BATEC
SCRAMBLER
dimensions

11a

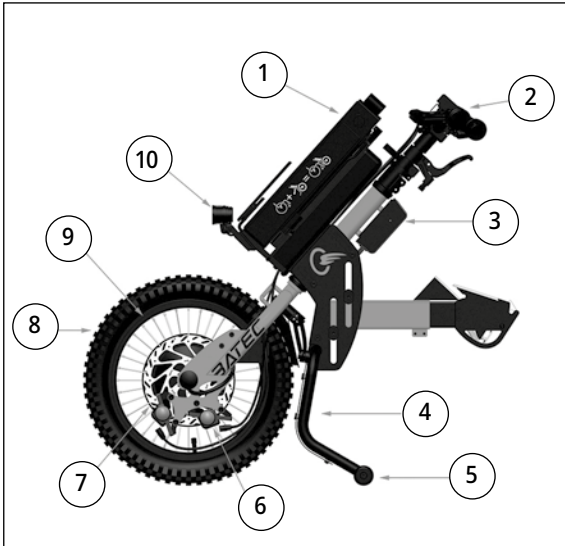

- 1. Battery
- 2. Handlebar
- 3. Controller
- 4. BATEC SAFE-FEET stand frame
- 5. Tail lights
- 6. Brake caliper
- 7. Disc brake
- 8. Tyre
- 9. Rim
- 10. Front light

11c

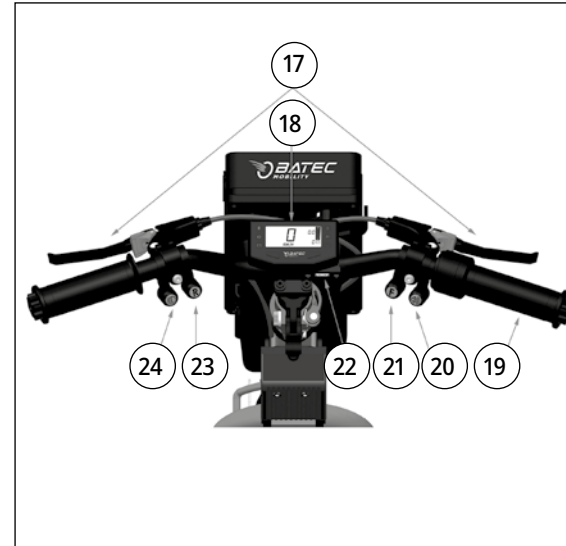

- 17. Brake levers
- 18. ALL-IN-ONE display panel
- 19. Twist throttle
- 20. Horn button
- 21. Front gear button
- 22. USB charging port
- 23. Reverse gear button
- 24. Lights button

11b

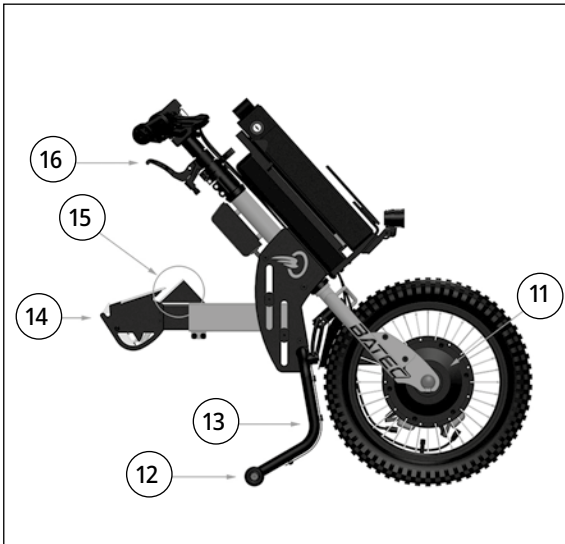

- 11. Motor
- 12. Rear wheels
- 13. Foot protector
- 14. Anchoring bar
- 15. Detaching ramp
- 16. Anchor lever

11d

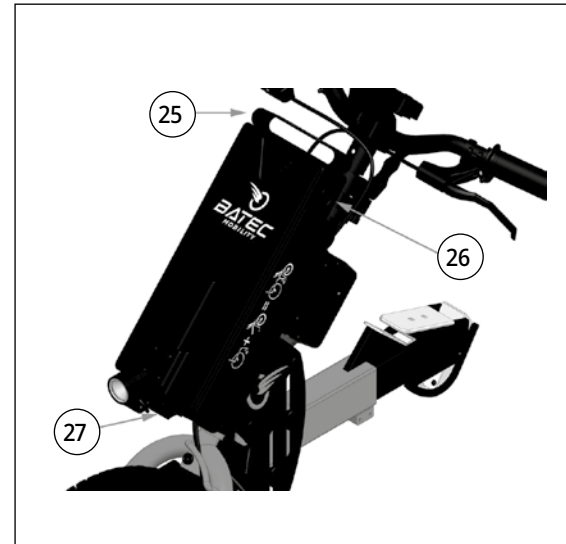

- 25. Handle
- 26. Charging port
- 27. Battery mount

11e

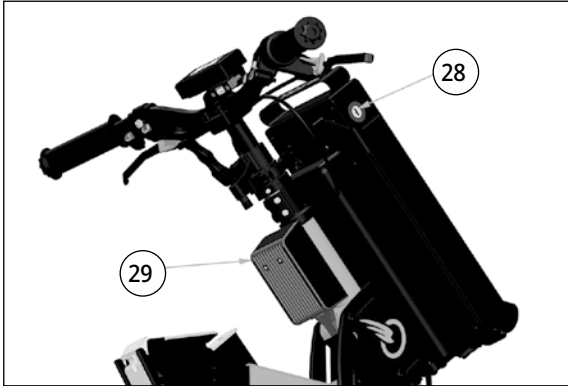

- 28. Key
- 29. Main control panel

11f

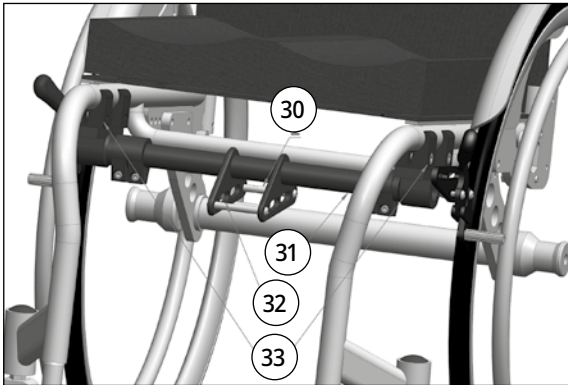

- 30. Rear axle of the BATEC DOCKING-BAR
- 31. BATEC DOCKING-BAR
- 32. Front axle of the BATEC DOCKING-BAR
- 33. Clamps

11g

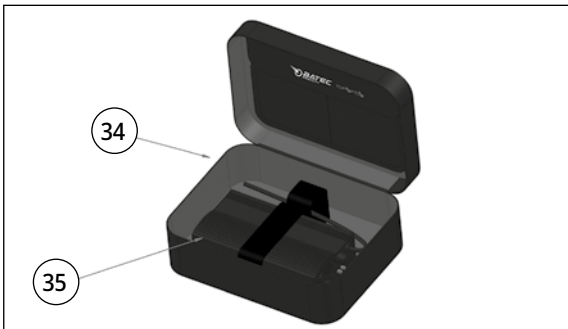

- 34. Bag
- 35. Charger

12

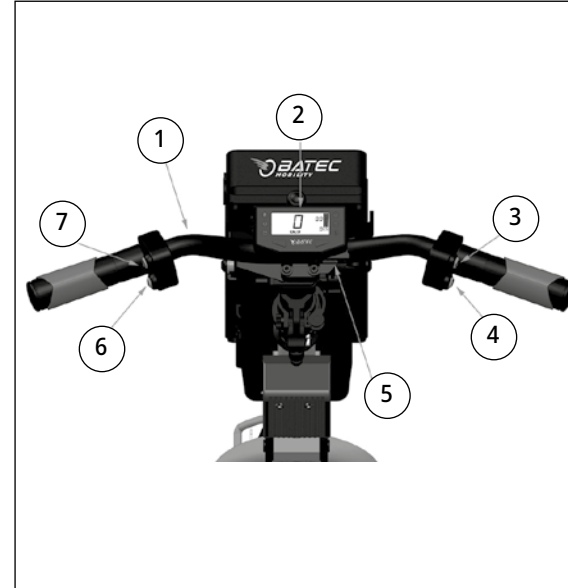

- 1. Gas and brake handle bar
- 2. Display Panel
- 3. Horn Button
- 4. Front gear button
- 5. USB charging port
- 6. Reverse gear button
- 7. Lights button

13

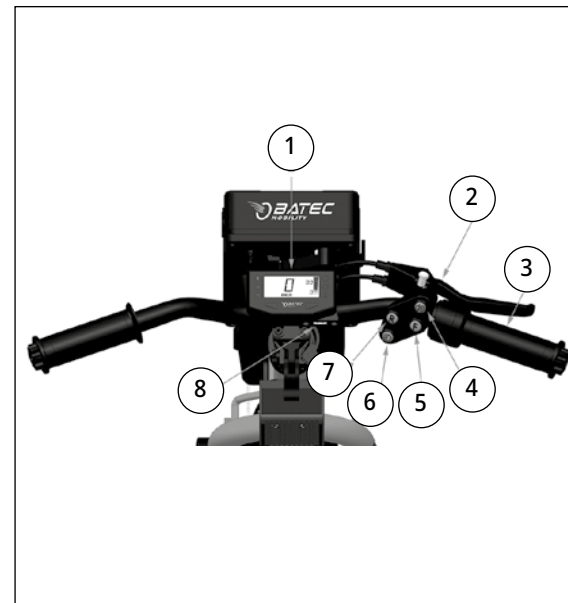

- 1. ALL-IN-ONE display panel
- 2. Double brake lever
- 3. Twist throttle
- 4. Horn button
- 5. Front Gear button
- 6. Lights button
- 7. Reverse gear button
- 8. USB charging port

14a



16a



14b

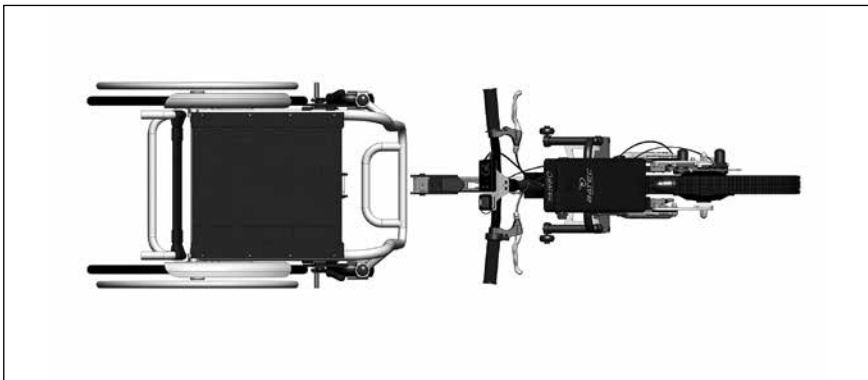

16b



15



17



18

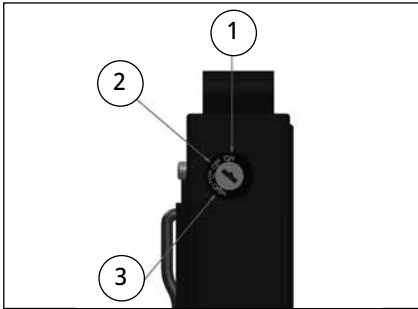

1. Turn on (ON)
2. Turn off and remove key with detaching lock (OFF)
3. Detach battery (OPEN)

22

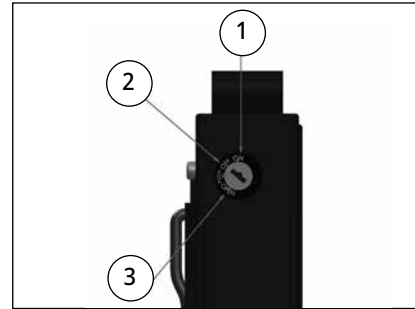

1. Turn on (ON)
2. Turn off and remove key with detaching lock (OFF)
3. Detach battery (OPEN)

19

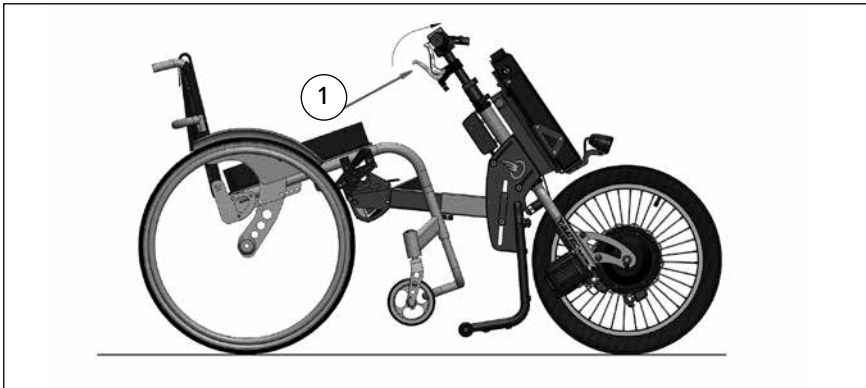

1. Anchor lever

23

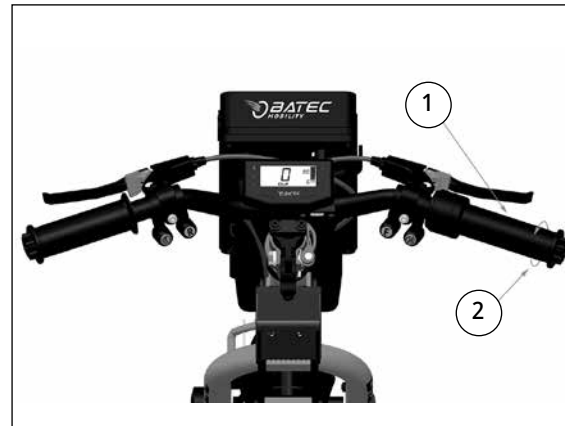

1. Twist throttle
2. Accelerate

20

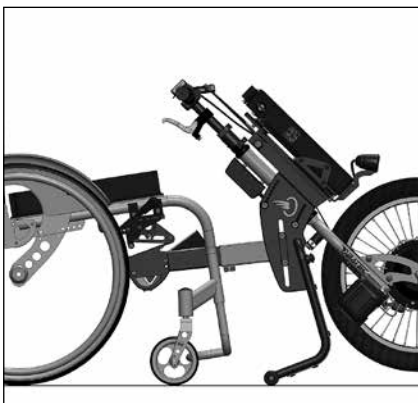

21

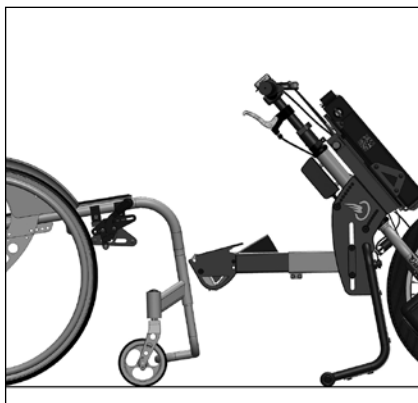

24

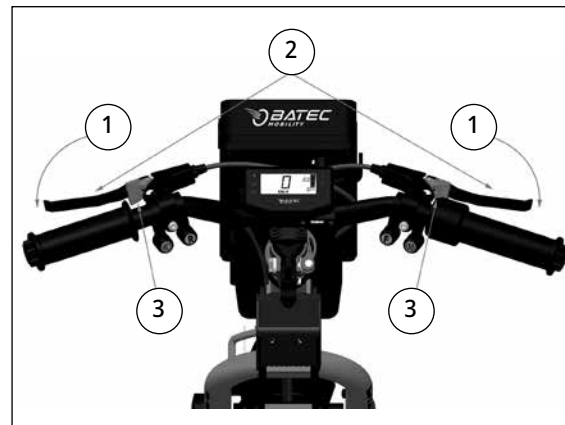

1. Braking
2. Brake lever
3. Parking brake

25

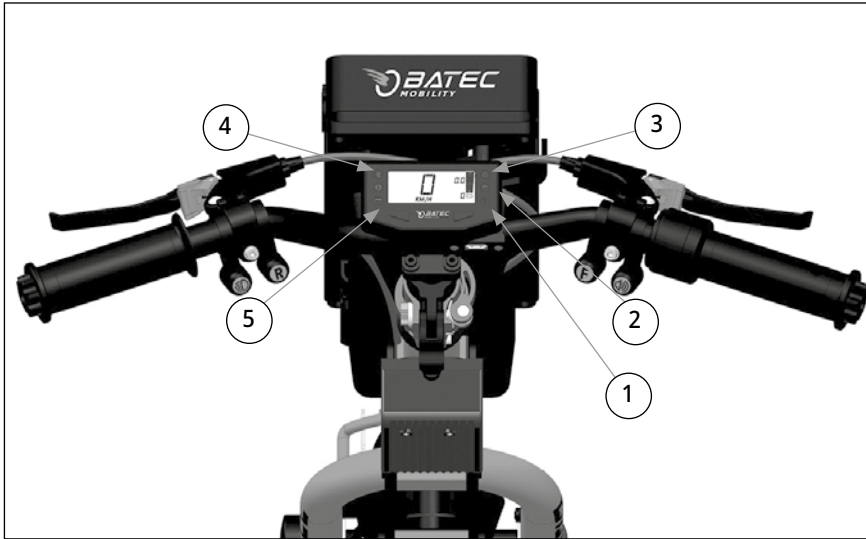

MINI 2 / MINI

- 1. Position 1: 6 km/h
- 2. Position 2: 15 km/h
- 3. Position 3: 20 km/h
- 4. Reverse gear
- 5. Low-battery indicator

ELECTRIC 2 (RAPID 2)

- 1. Position 1: 6 km/h (6)
- 2. Position 2: 15 km/h (15)
- 3. Position 3: 25 km/h (30)
- 4. Reverse gear
- 5. Low-battery indicator

SCRAMBLER

- 1. Position 1: 6 km/h
- 2. Position 2: 15 km/h
- 3. Position 3: 20 km/h
- 4. Reverse gear
- 5. Low-battery indicator

26a

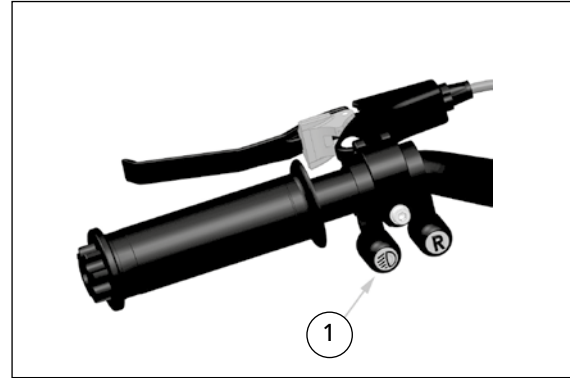

1. Lights switch

26b

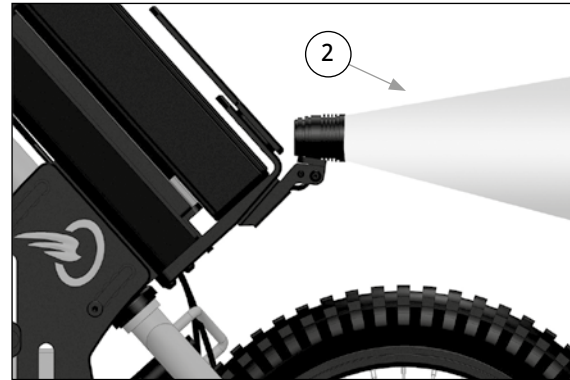

2. Lights on

26c

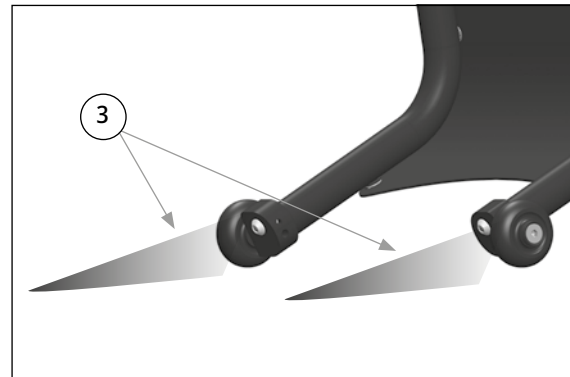

3. Rear lights

27

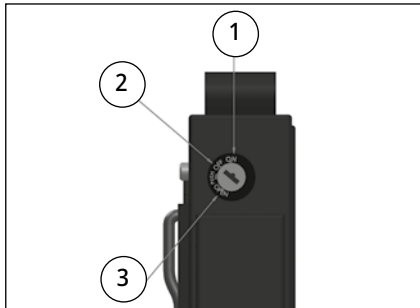

1. Turn on (ON)
2. Turn off and remove key with detaching lock (OFF)
3. Detach battery (OPEN)

28

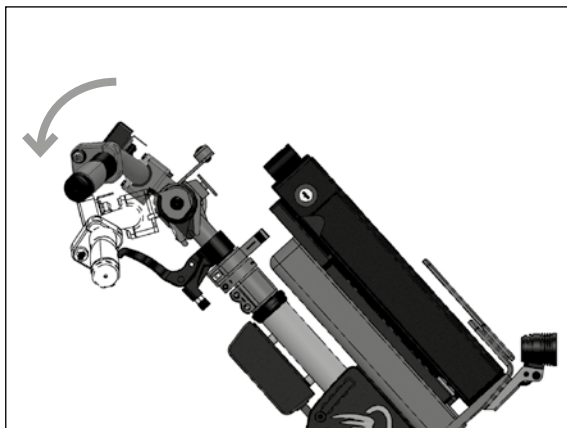

1. Accelerate

29

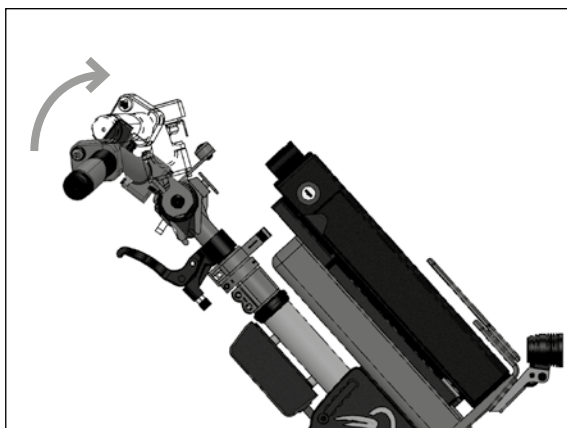

1. Braking

30

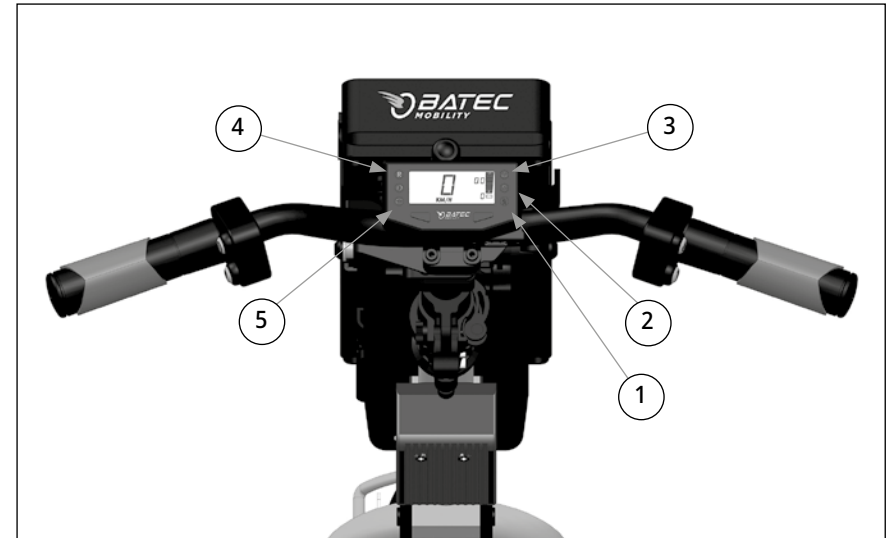

MINI 2 / MINI

1. Position 1: 6 km/h
2. Position 2: 15 km/h
3. Position 3: 20 km/h
4. Reverse gear
5. Low-battery indicator

ELECTRIC 2 (RAPID 2)

1. Position 1: 6 km/h (6)
2. Position 2: 15 km/h (15)
3. Position 3: 25 km/h (30)
4. Reverse gear
5. Low-battery indicator

SCRAMBLER

1. Position 1: 6 km/h
2. Position 2: 15 km/h
3. Position 3: 20 km/h
4. Reverse gear
5. Low-battery indicator

31a

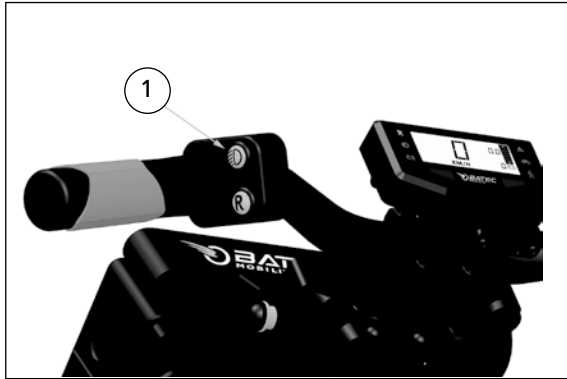

1. Lights switch

31b

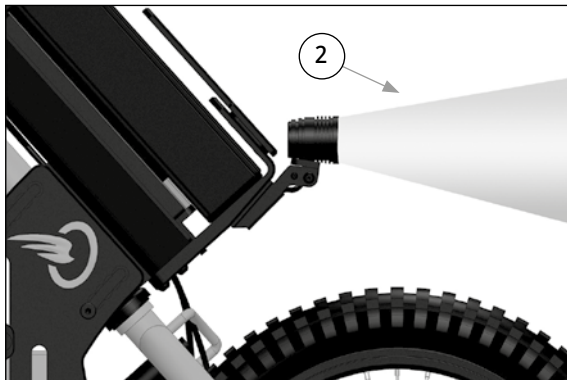

2. Lights on

31c

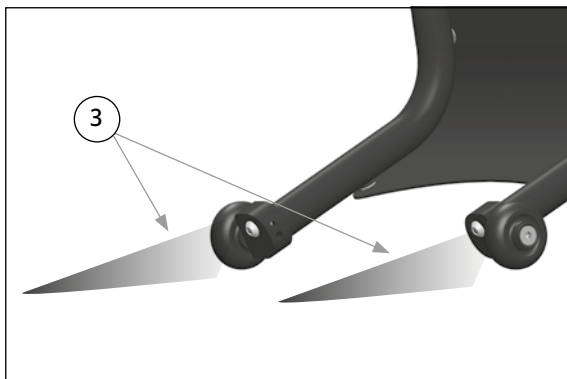

3. Rear lights

32

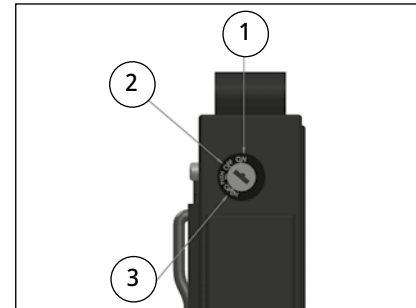

1. Turn on (ON)
2. Turn off and remove key with detaching lock (OFF)
3. Detach battery (OPEN)

33

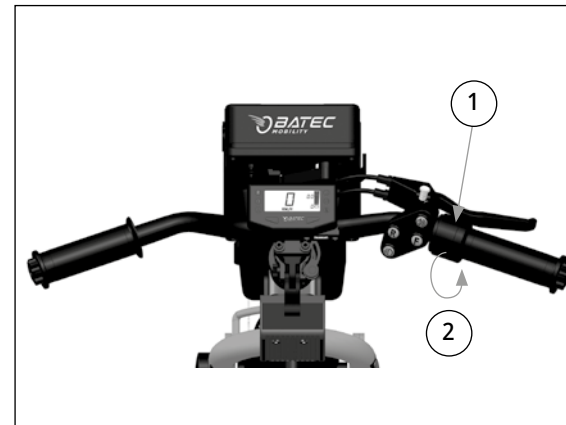

1. Twist throttle
2. Accelerate

34

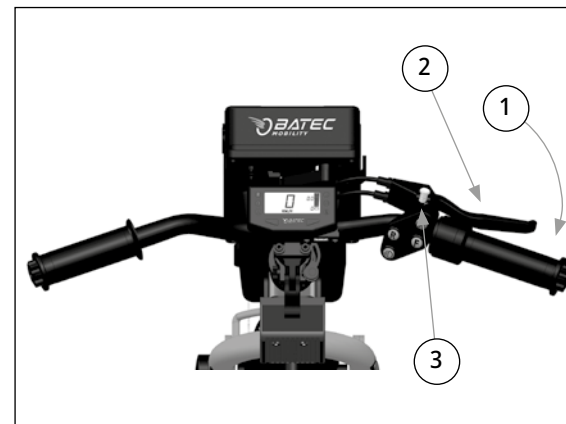

1. Braking
2. Brake lever
3. Parking brake

35

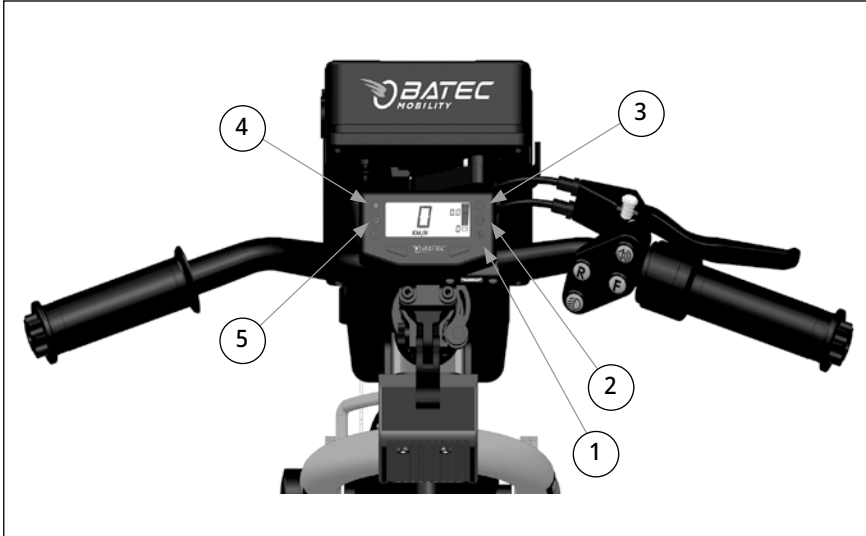

MINI 2 / MINI

- 1. Position 1: 6 km/h
- 2. Position 2: 15 km/h
- 3. Position 3: 20 km/h
- 4. Reverse gear
- 5. Low-battery indicator

ELECTRIC 2 (RAPID 2)

- 1. Position 1: 6 km/h (6)
- 2. Position 2: 15 km/h (15)
- 3. Position 3: 25 km/h (30)
- 4. Reverse gear
- 5. Low-battery indicator

SCRAMBLER

- 1. Position 1: 6 km/h
- 2. Position 2: 15 km/h
- 3. Position 3: 20 km/h
- 4. Reverse gear
- 5. Low-battery indicator

36a

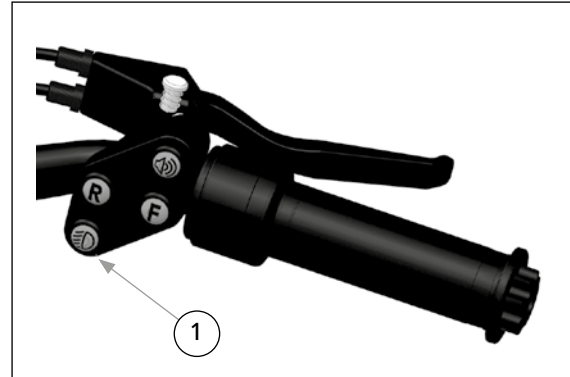

1. Lights switch

36b

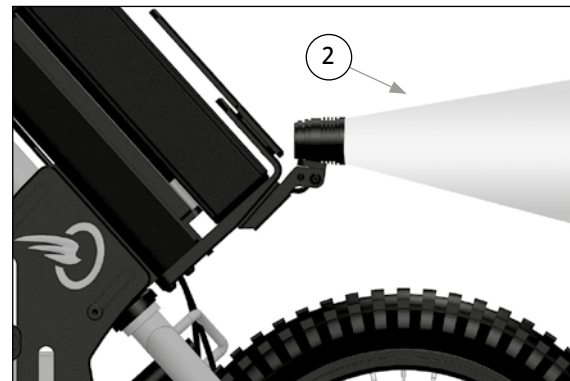

2. Lights on

36c

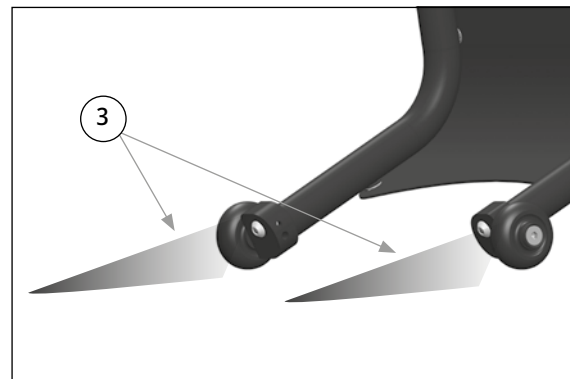

3. Rear lights

37

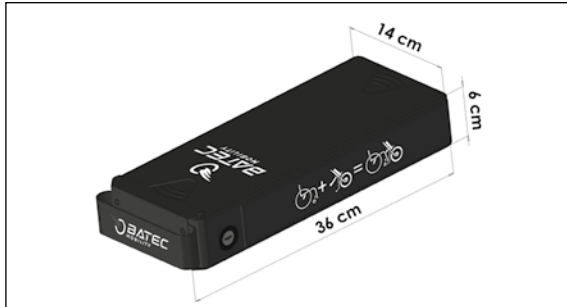

38

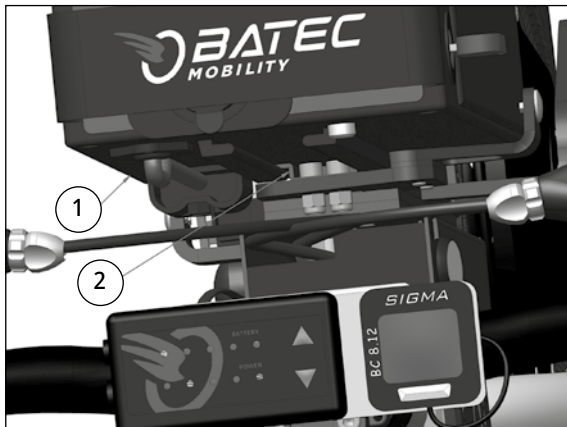

- 1. Battery
- 2. Battery guide

39



40



41

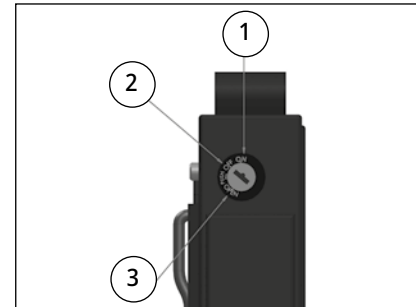

- 1. Turn on (ON)
- 2. Turn off and remove key with detaching lock (OFF)
- 3. Detach battery (OPEN)

42

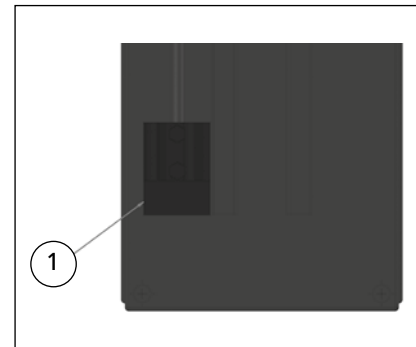

- 1. Discharging port

43

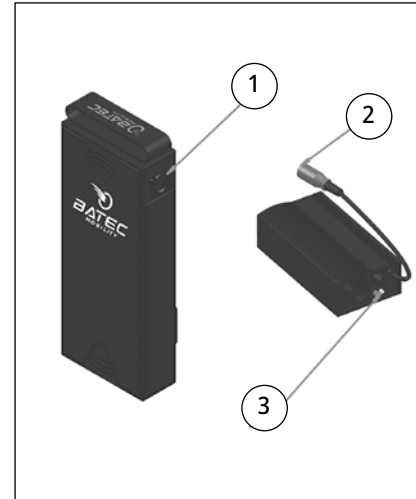

- 1. Charging port
- 2. Connect to charging port
- 3. Green light, charger plugged in / Orange light, charging / Green light, fully charged

44



45



46



47



48

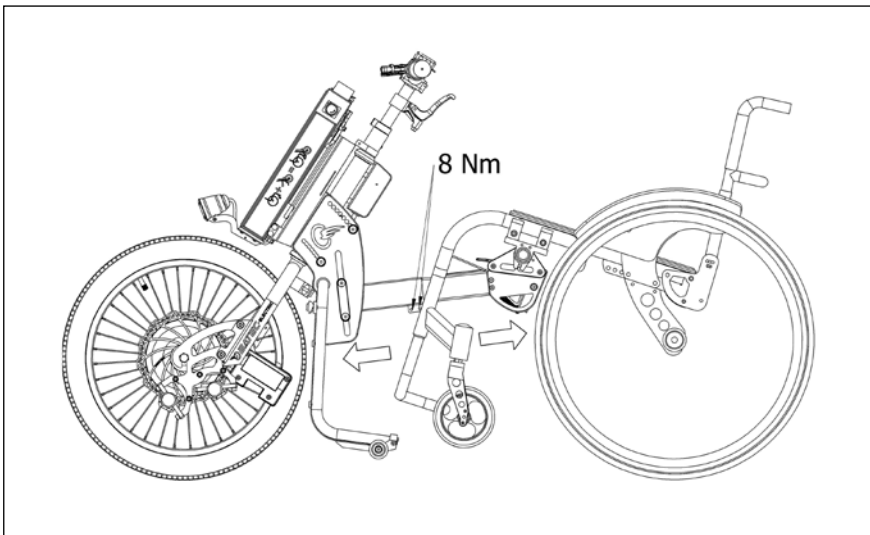

49

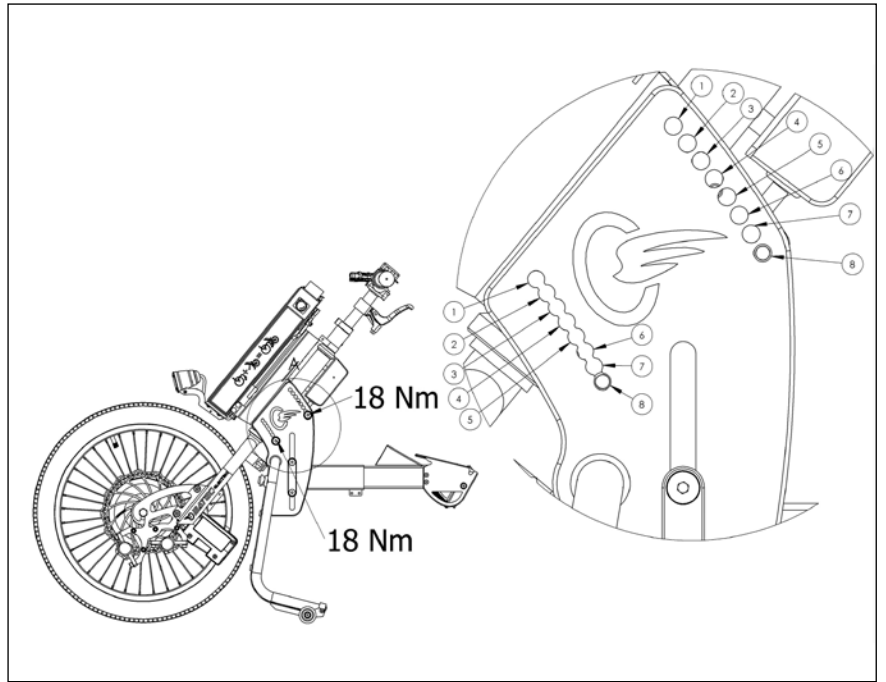

50

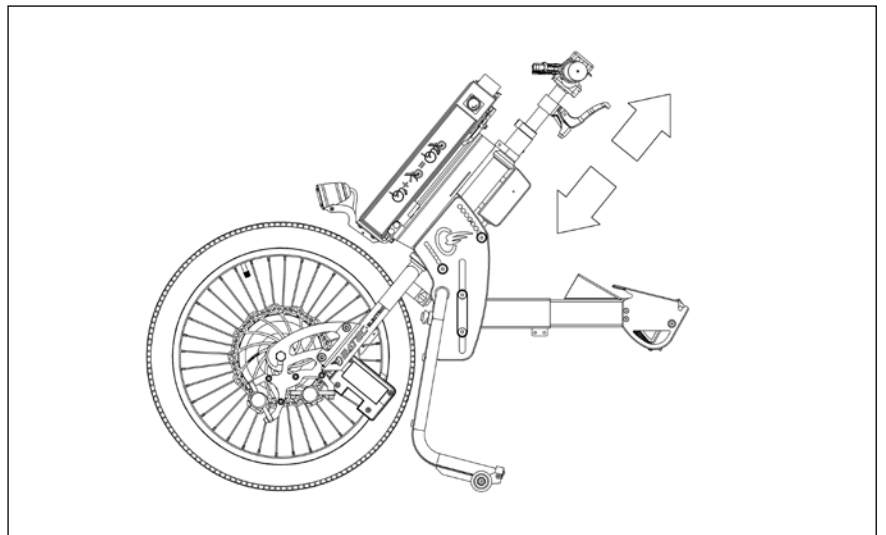

51



52



53



54



55



56



57

BATEC MOBILITY S.L.
Illa de Buda, 2 - 08192 Sant Quirze del Valles
(Barcelona) SPAIN | T +34 93 544 2003
info@batec-mobility.com | www.batec-mobility.com

KG
max. 110 kg

MD
Medical Device

PRODUCT	
REF	
SN	

PNT-013/8.0

58

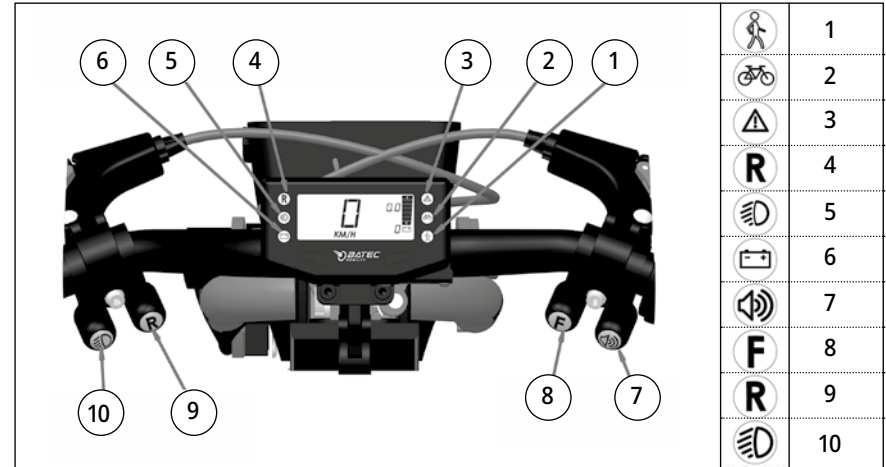

1. Light indicator Position 1
2. Light indicator Position 2
3. Light indicator Position 3
4. Light indicator Reverse
5. Light indicator Lights
6. Light indicator Low battery
7. Button Horn
8. Button Go forward
9. Button Reverse
10. Button Lights

